

REVISION RECORD				
REV	ECN	DESCRIPTION	DRFT	DATE

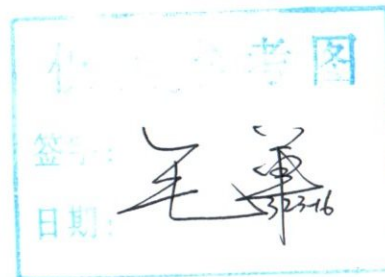
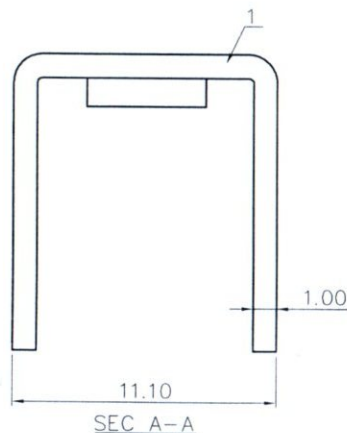
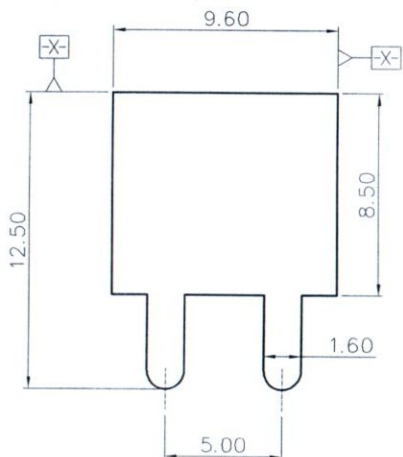
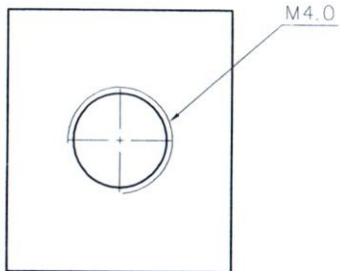

NOTES1:
 UL Standard
 1.Rated Current : 40A
 2.Torque Value : M4 , 10.53Lb.in

NOTES2:
 1.Dimension shall be interpreted per ASME Y14.5-2009
 2.Undimensioned Tolerances:

Pitch Range In mm	Nominal Dimension Range In mm						-	∩	∇
	Over 6 TO 6	Over 10 TO 10	Over 30 TO 30	Over 60 TO 60	Over 100 TO 100	Over 150 TO 150			
±0.15	±0.20	±0.30	±0.30	±0.50	±0.70	±1.00	±1.30	±2'	

3.RoHS Compliance

ITEM	NAME OF PART	MATERIAL	NOTES
1	PIN HEADER	COPPER ALLOY	Sn Plated

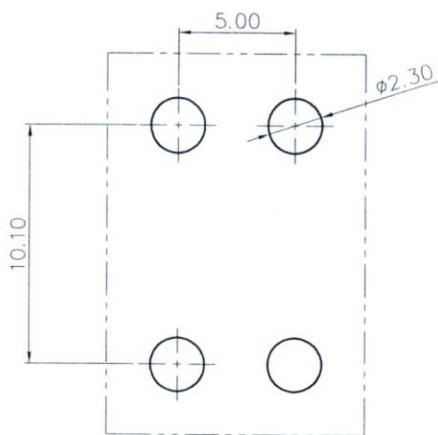

PCB LAYOUT

DETACHED LISTS	PART NO.:	宁波高松电子有限公司 DEGSON [®] NINGBO DEGSON ELECTRICAL CO., LTD		
	APPD: Aaron 3/23/16	NAME: K31-00A(H)		
	CHKD: XXY 03/22/16	TITLE: CUSTOMER DRAWING		
	DRFT: XXY 03/22/16	REV	T0-1	
	THIRD ANGLE PROJECTION	DRAWING NO.: K31-C01	SHEET	1/1

MM (INCH)	DO NOT SCALE DRAWING	SCALE	1:1
-----------	----------------------	-------	-----