

HumiChip®

Humidity & Temperature Solution

Features

- ♦ Fully Calibrated & Temperature Compensated
- ♦ Digital or Analog Output with Alarm Function
- ♦ Precision & Accuracy ($\pm 2\%RH$, $\pm 0.3^{\circ}C$, 14 bit)
- ♦ Free Operating Voltage (min 2.3V to max 5.5V)
- ♦ Low Current Consumption
- ♦ SMD Package for Automated Assembly
- ♦ Reliable in Harsh Environment



Product Summary

HumiChip® offers the most advanced and cost effective humidity and temperature sensing solution for virtually any type of applications.

Capacitive polymer sensor chip developed and fabricated in-house and CMOS integrated circuit with EEPROM are integrated into one embedded system in a reflow solder-able SMD package.

Individually calibrated and tested, **HumiChip®** performs $\pm 2\%$ from 20% to 80%RH ($\pm 3\%$ over entire humidity range), and yet, is simple and ready to use without further calibration or temperature compensation.

HumiChip® provides linear output signals in various interfaces to customer requirements - the **standard I²C interface**, **PDM** convertible to analog signal, and an **Alarm function** for preset control at min/max humidity.

Designed and manufactured by industry leading humidity and temperature sensing technology of **SAMYOUNG S&C** – field proven in HVAC and Auto industry for over 10 years, **HumiChip®** offers another sensible sensing solution for excellent reliability, high accuracy, and cost effective sensing applications.

Application

Energy Saving HVAC Control

Air Conditioning, Refrigeration, IAQ monitoring, Vent Fans, Home Appliances, Humi/Dehumidifiers

Process Control & Instrumentations

Medical Instruments, Handheld Devices, Weather Stations, Food Processing, Printers, RFIDs ...

Automobile & Transportation

Cabin Climate Control, Defogging Control
Condensing Preventive Device ...

Mass Quantity Application

OEM custom specification available

Sensor Performance

Relative Humidity (RH%)

* Custom Accuracy Tolerance Available

Resolution	14 bit (0.01%RH)
Accuracy ¹	±2.0 %RH (20~80%RH)*
Repeatability	±0.2 %RH
Hysteresis	±2.0 %RH
Linearity	<2.0 %RH
Response time ²	7.0 sec (τ 63%)
Temp Coefficient	Max 0.13 %RH/°C (at 10~60°C, 10~90%RH)
Operating range	0 ~ 100 %RH (Non-Condensing)
Long term drift	<0.5 %RH/yr (Normal condition)

Figure 1. Typical RH% Accuracy at 25 °C

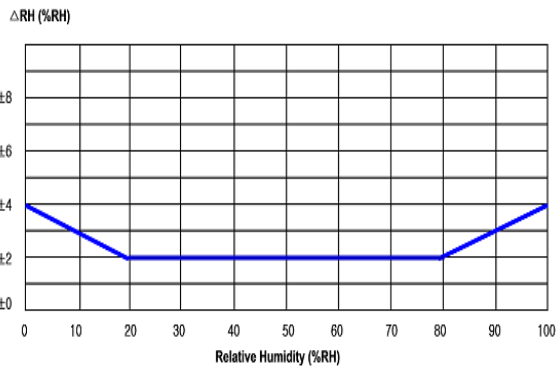

Temperature (°C)

Resolution	14 bit (0.01°C)
Accuracy ³	±0.3 °C (Figure 2)
Repeatability	±0.1 °C
Response time ⁴	5.0 sec (τ 63%)
Operating range	- 40 ~ 125 °C
Long term drift	<0.05 °C/yr (Normal condition)

1. Accuracies measured at 25 °C, 5.0V.
2. Measured at 25 °C, 1m/sec airflow for achieving 63% of step from 33%RH to 90%RH
3. Accuracies measured at 25 °C, 5.0V.
4. Min 5.0 sec, Max 20 sec

Figure 2. Typical Temperature Accuracy

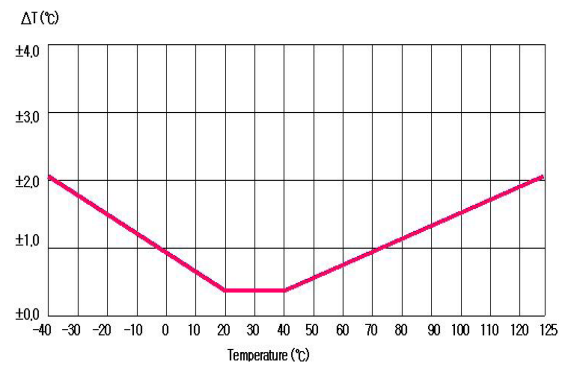

Dimensions

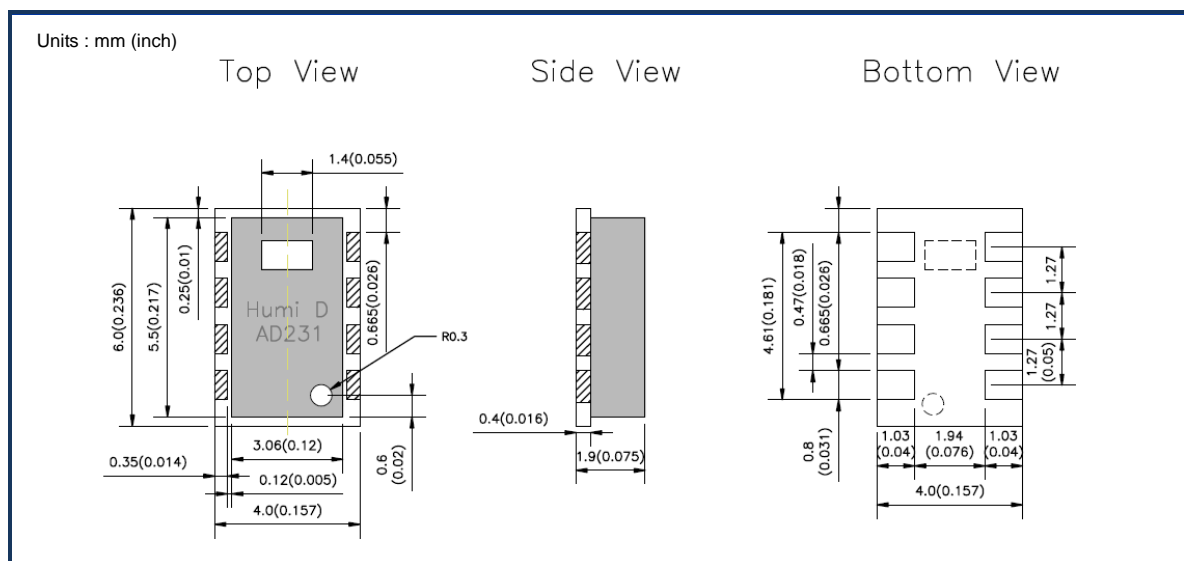

Electrical Specification

Supply Voltage ^{*1}	min 2.3V ~ max 5.5V
Supply Current (I _{DD})	750 μ A (typical)
Sleep Current (I _{sleep}) ^{*2}	0.6 μ A (typical)

*1. Lower than 2.7V supply voltage may increase the accuracy tolerance of the Temperature.

*2. at -40 ~ 85°C

Pin Connection

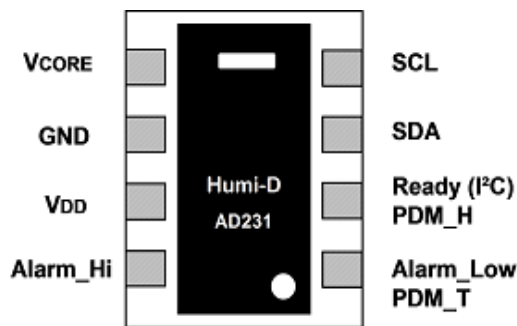

Environmental

Operating Temperature	- 40 ~ 125 °C
Operating Humidity	0~100%RH (non condensing)

Absolute Maximum Rating

Parameter	Min	Max
Supply Voltage (V _{DD})	-0.3V	6.0V
Storage Temp	-55 °C	150 °C
Junction Temp	-55 °C	150 °C

Soldering Information

Standard or IR Solder Reflow.

T_p: 260 °C, t_p: 40 sec. (qualify Pb free profile)

Package Contents

Capacitive polymer RH Sensor,
 PTA (Proportional to Absolute) Temperature sensor
 integrated ASIC chip in LCC (Leadless Chip Carrier)
 package, SMD.

RoHS Compliant

Shipping

Reel & Tape: 2,500 / 500 ea

Ordering Information

Output	Accuracy	V _{DD}	MODE	Ordering P/N	
D	I ² C	±2%RH	3.3	Update	HCPD- 3V-U2
		±3%RH	5.0		HCPD- 5V-U3
		±2%RH	3.3	Sleep	HCPD- 3V-S2
		±3%RH	5.0		HCPD- 5V-S3
A	PDM	±2%RH	3.3	Update	HCPA- 3V-U2
		±3%RH	5.0		HCPA- 5V-U3

➤ Standard **Digital (I²C)** Output :

Factory setting is **Sleep Mode** and calibrated at **3.3V**.

Humidity, Temperature, and 2 Alarm (Hi / Low) functions for relative humidity.

➤ Standard **Analog (PDM)** Output :

Update Mode is calibrated at **5.0V**.

Humidity, Temperature, and an Alarm (high) function.

◆ For more detail **Part Numbers**,
 Please refer to the **Table 7-1**

Application Guide

CONTENTS

1. General Information

1.1	Preliminary Consideration	7
1.2	Operating Conditions	7
1.3	Heating	7
1.4	Soldering Instruction	7
1.5	Storage and Handling Information	8
1.6	Reconditioning Procedure	8
1.7	Material Contents	8
1.8	Traceability Information	8
1.9	Shipping Package	9

2. Interface Specification

2.1	Digital Output (I ² C Interface)	10
2.1.1	Power Pads	10
2.1.2	Serial Clock & Data Pads	10
2.1.3	Alarm Pads	10
2.2	Analog Output (PDM)	12
2.2.1	Power Pads	12
2.2.2	PDM Output Pads	12
2.2.3	Alarm Pads	12
2.2.4	Serial Clock & Data Pads	13
2.2.5	Typical Circuit Connection	13

3. Electrical Specification

3.1	Absolute Maximum Rating	14
3.2	Electrical Specification & Recommended Operating Condition	14
3.3	Output Pad Drive Strength	14
3.4	ESD / Latch-Up Protection	14

4. Communicating with HumiChip®

4.1	Power-On Sequence	16
4.2	I ² C Features and Timing	16
4.3	Measurement Mode	18
4.3.1	DF in Update Mode	18
4.3.2	DF in Sleep Mode	18
4.4	Status Bits	20
4.5	I ² C Commands	20
4.6	Data Fetch (DF)	20
4.7	Measurement Request (MR)	22
4.8	Ready Pin	22
4.9	Command Mode	22
4.10	Command Encodings	23
4.11	Command Response and Data Fetch	24
4.12	EEPROM	25

5. Converting PDM to Analog Signal

5.1	PDM (Pulse Density Modulation)	27
5.2	Low Pass Filtering	27
5.3	Analog Output Characteristics	28
5.3.1	Polynomial Equation Humidity	28
5.3.2	Polynomial Equation Temperature)	28

6. Alarm Function (Optional)

6.1	Alarm Output	29
6.2	Alarm Registers	29
6.3	Alarm Operation	29
6.4	Alarm Output Configuration	29
6.5	Alarm Polarity	29

List of Tables and Figures

Tables

Table 3.1	Absolute Maximum Rating		14
Table 3.2	Recommended Operating Conditions		14
Table 3.3	Electrical Characteristics Specifications		15
Table 3.4	Output High Drive Strength	16	
Table 3.5	Output Low Drive Strength		16
Table 4.1	I ² C Parameters		17
Table 4.2	Status Bits		20
Table 4.3	I ² C Commands Bits		20
Table 4.4	Command List and Encodings		23
Table 4.5	Response Bits		24
Table 4.6	Command Diagnostic Bits		24
Table 4.7	EEPROM Word Assignments		25
Table 5.1	Low Pass Filter Example		27
Table 6.1	Cust_Config Bit Assignments		32
Table 7.1	HumiChip Part Number List		33

Figures

Figure 1.1	Operating Conditions		7
Figure 1.2	Soldering Profile		7
Figure 1.3	Laser Marking		8
Figure 2.1	Typical Application Circuit(I2C)		11
Figure 2.2	Typical Application Circuit(PDM)		13
Figure 4.1	Power-On Sequence with Fast Startup Bit Set in EEPROM		17
Figure 4.2	I ² C Timing Diagram		17
Figure 4.3	I ² C Measurement Packet Reads		21
Figure 4.3.1	I ² C Data Fetching in Update Mode		18
Figure 4.3.2	Measurement Sequence in Sleep Mode		19
Figure 4.3.3	I ² C Data Fetching in Sleep Mode		19
Figure 4.4	I ² C Measurement Request		22
Figure 4.5	I ² C Command Format		23
Figure 4.6	Command Mode Data Fetch		25
Figure 5.1	PDM Signal Timing Diagram		27
Figure 6.1	Bang-Bang Humidity control : PDM		30
Figure 6.2	Bang-Bang Humidity control : I2C		30
Figure 6.3	LED control with Alarm fuction : PDM		31
Figure 6.4	Example of Alarm Function		31
Figure 6.5	Alarm Output Flow Chart		32

Drawings

Drawing 1.	Land Pattern		9
Drawing 2.	Packing Reel & Tape		9
Drawing 3.	Packing (Box)		9

<u>Humidity and Temperature Conversion Formula</u>			21
---	--	--	----

👉 **Demo Kit** (EVB01-HCP) is available.

A reference program source code can be downloaded from www.samyoungsnc.com

1. General Information

1.1 Preliminary Consideration

To maximize the performance of **HumiChip®**, it is important to plan an appropriate location of the sensor at the design stage. Airflow and proper exposure to ambient air must be secured for **HumiChip®** to ensure expected performance. Airflow holes must NOT be blocked. Any heat

generating parts near **HumiChip®** will distort the proper measurement of relative humidity and temperature reading, and either should be avoided or measures should be taken to prevent heat transfer.

1.2 Operating Conditions

HumiChip®'s maximum and recommended normal operating condition is shown below (**Figure 1.1**). Within the Normal Range **HumiChip®** performs stable. Prolonged exposures to conditions outside normal range, especially at humidity over 90%RH, may temporarily offset the RH signal up to $\pm 3\%$ RH. When return to Normal Range, it will gradually recover back to the calibration state.

Re-Conditioning Procedure in **section 1.6** will help reduce this recovery time. Long term exposure to extreme conditions may also accelerate aging of the sensor.

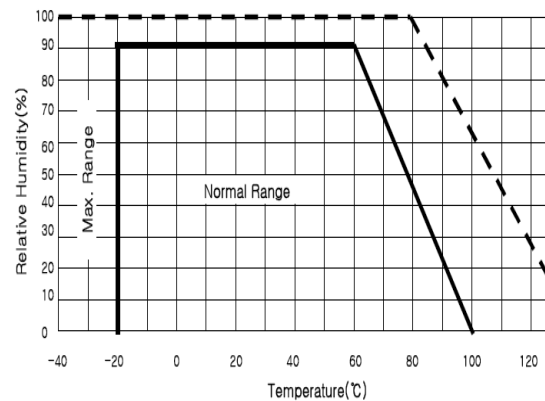

Figure 1.1 Operating Conditions

1.3 Heating

Though within the accuracy tolerance, Self-Heating in the sensor IC may affect accurate measurement of temperature and RH%. The measurement error from Self Heating can be reduced by keeping 'Active State' to the minimum, and by regulating the operating voltage within $3.3 \pm 0.5V$ or $5.0 \pm 0.5V$. In order to minimize the self heating, sampling time should be more than 180ms. (200ms

recommended)
Other heat sources such as power electronics, microcontrollers, and display near the sensor may affect the accurate measurement. The location of Sensor near such heat sources should be avoided by maintaining distance or thermal buffer. Thin metal pattern, or even better, 'milling slits' around the sensor also may help reduce the error.

1.4 Soldering Instruction

HumiChip® is designed for mass production reflow soldering process. It is qualified for soldering profile according to IPC/JEDEC J-STD-020D (see **Figure 1.2**) for Pb-free assembly in standard reflow soldering ovens or IR/Convection reflow ovens to withstand peak temperature at $240^\circ C$ and peak time up to 40 sec. For soldering in Vapor Phase Reflow (VPR) ovens the peak conditions are limited to $T_P < 240^\circ C$ with $t_P < 40sec$ and ramp-up/down speeds shall be limited to $10^\circ C/sec$. For manual soldering, contact time should not exceed 4 seconds at up to $350^\circ C$. No-Clean solder flux should be used.

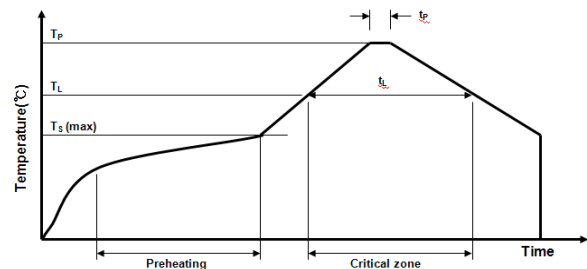

Figure 1.2 Soldering Profile

IPC/JEDEC standard

$T_P \leq 240^\circ C$, $t_P < 40sec$, $T_L < 200^\circ C$, $t_L < 150sec$.

Ramp-up/down speed $< 5^\circ C/sec$.

Important: Test or measurement right after soldering may read an offset as the sensor needs time for Hydration. The recovery time may vary depending on reflow soldering profile and ambient storage condition.

If the offset exceeds accuracy range, the following Hydration process will bring the sensor back within original accuracy range.

1.5 Storage and Handling Information

HumiChip® contains polymer based capacitive humidity sensor sensitive to environment, and should NOT be handled as an ordinary electronic component.

Chemical vapors at high concentration may interface with the polymer layers, and coupled with long exposure time, may cause a shift in both offset and sensitivity of the sensor.

Despite the sensor endures the extreme conditions of -55°C~150°C, 0%~100%RH (non condensing), long term exposure in such environment may also

1.6 Reconditioning Procedure

If **HumiChip®** is exposed to extreme conditions or contaminated with chemical vapors, the following reconditioning procedure will recover the sensor back to calibration state.

1.7 Material Contents

HumiChip® consists of sensor cell and IC (polymer / glass & silicon substrate) packaged in a surface mountable LCC (Leadless Chip Carrier) type package. The sensor housing consists of a PPS (Poly Phenylene Sulfide) cap with epoxy glob top on

1.8 Traceability Information

HumiChip® is laser marked with product type and lot identification.

Further information about individual sensor is electronically stored on the chip.

The first line denotes the sensor type: **HUMI-A** for PDM output, **HUMI-D** for I²C output.

Lot identification is printed on the second line with 5 digit alphanumeric code.

An electronic identification code stored on the chip can be decoded by **Samyoung S&C** only and allows for tracking on batch level through production, calibration and testing.

Hydration: 32±2°C 85±5%RH, Duration: 45±5hrs (None Baking, Max time(50hrs) recommended)

Contact our **customer support** for customized recovery measures specific to your reflow soldering process. [support@samyoungsnc.com]

For **Land Pattern** drawing & dimensions, see **Drawing 1** on page 9.

offset the sensor reading. Hence, once the package is opened, it is recommended to store in clean environment of temperature at 5°C~55°C and humidity at 10%~70%RH.

HumiChip® is protected of ESD up to 4000V and Latchup of ±100mA or (up to +8V / down to -4V) relative to VSS/VSSA, and also packed in ESD protected shipping material. Normal ESD precaution is required when handling in assembly process.

Baking: **80±2°C for 24±2hrs** and
 Hydration: **32±2°C 85±5%RH for 45±5hrs**
(Max 50hrs recommended)

a standard FR4 substrate. Pads are made of Au plated Cu. The device is free of Pb, Cd and Hg.

RoHS compliant / REACH report available

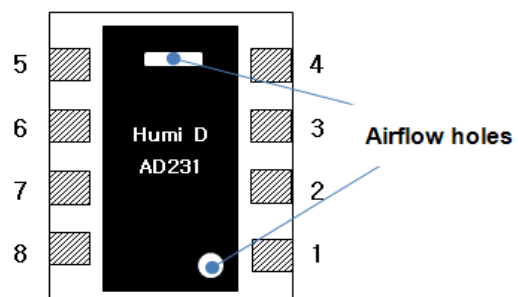

Figure 1.3 Laser Marking

1.9 Shipping Package

HumiChip® is provided in a tape & reel shipment packaging, sealed into antistatic ESD trays. Standard packaging sizes are 2,500 or 500 units per

reel. The drawing of the packaging tapes with sensor orientation and packing box dimensions are shown in **Drawing 2** and **Drawing 3** below.

Drawing 1 Land Pattern

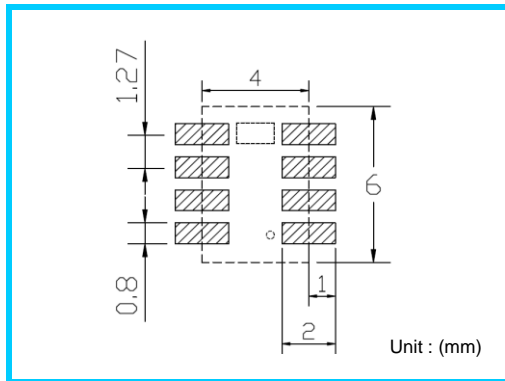

Drawing 2 Packing Reel & Tape

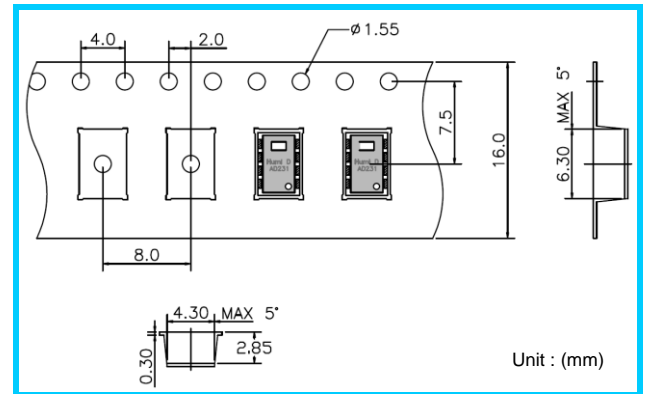

Drawing 3 Packing (Box)

Inbox: 500ea

Dimension: 215 x 210 x 30 mm

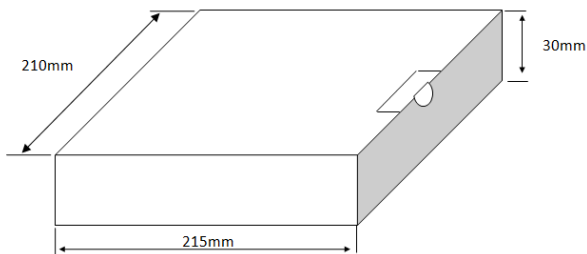

Inbox: 2,500ea

Dimension: 360 x 355 x 50 mm

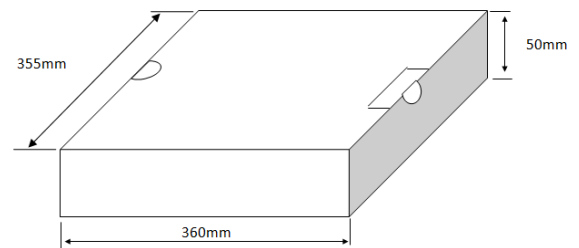

Outbox: 5,000ea (5 x Inbox 500)

Dimension: 320 x 225 x 235 mm

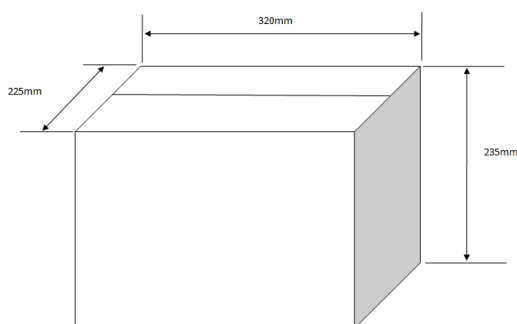

Outbox: 20,000ea (8 x Inbox 2500)

Dimensions: 420 x 370 x 385 mm

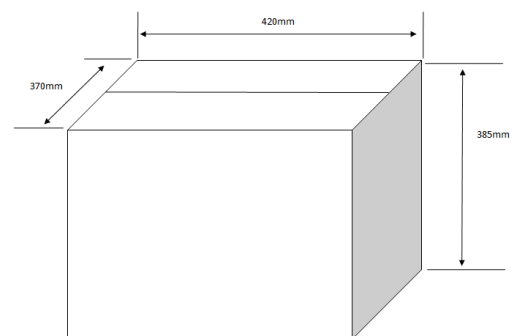

2. Interface Specification

2.1 Digital Output (I²C Interface)

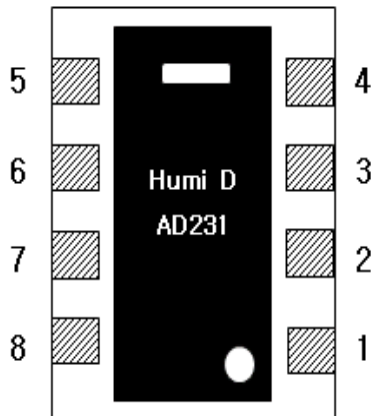

Pin-No	Name	Description
1	Alarm_low	Low alarm output
2	Ready	Ready signal (conversion complete output)
3	SDA	I ² C data
4	SCL	I ² C clock
5	V _{CORE}	Core voltage
6	VSS	Ground supply
7	VDD	Supply voltage (2.3-5.5V)
8	Alarm_High	High alarm output

2.1.1 Power Pads (5.V_{CORE}, 6.VSS, 7.VDD)

HumiChip[®] is capable of operating on wide range of power supply voltage from 2.3V to 5.5V. Recommended supply voltage is either 3.3±0.5V or 5.0±0.5V. Power supply should be connected to VDD (power supply pad 7). VDD and VSS (Ground

pad 6) should be decoupled with a 220nF capacitor.

Important: Vcore must not be connected to VDD, and it must always be connected to an external 100nF capacitor to ground. (see [Figure 2.1](#))

2.1.2 Serial Clock & Data Pads (3. SDA, 4. SCL)

The sensor's data is transferred in and out through the SDA pad while the communication between **HumiChip[®]** and microcontroller (MCU) is synchronized through the SCL pad. **HumiChip[®]** has an internal temperature compensated oscillator that provide time base for all operation, and uses an I²C-compatible communication protocol with support for 20 KHz to

400 KHz bit rates.

External pull-up resistors are required to pull the drive signal high, that can be included in I/O circuits of microcontroller. (see [Figure 2.1](#))

Further information about timing and communication between the sensor and microcontroller is explained in Section 4. Communicating with **HumiChip[®]**.

2.1.3 Alarm Pads (1. Alarm Low, 8. Alarm High)

The alarm output can be used to monitor whether the sensor reading has exceeded or fallen below pre-programmed values. The alarm can be used to drive an open-drain load connected to VDD, or it can function as a full push-pull driver. If a high voltage application is required, external devices can

be controlled with the Alarm pins, as demonstrated in [Figure 6.2](#).

The two alarm outputs can be used simultaneously, and these alarms can be used in combination with the I²C. Further information about Alarm control is explained in **Section 6**.

Figure 2.1 Typical Application Circuit (I2C)

- VDD and Ground is decoupled by a 220nF capacitor.
- Vcore (Not Used) and Ground is decoupled by 100nF capacitor.
- Pull-up resistors should be included between **HumiChip®** and MCU.

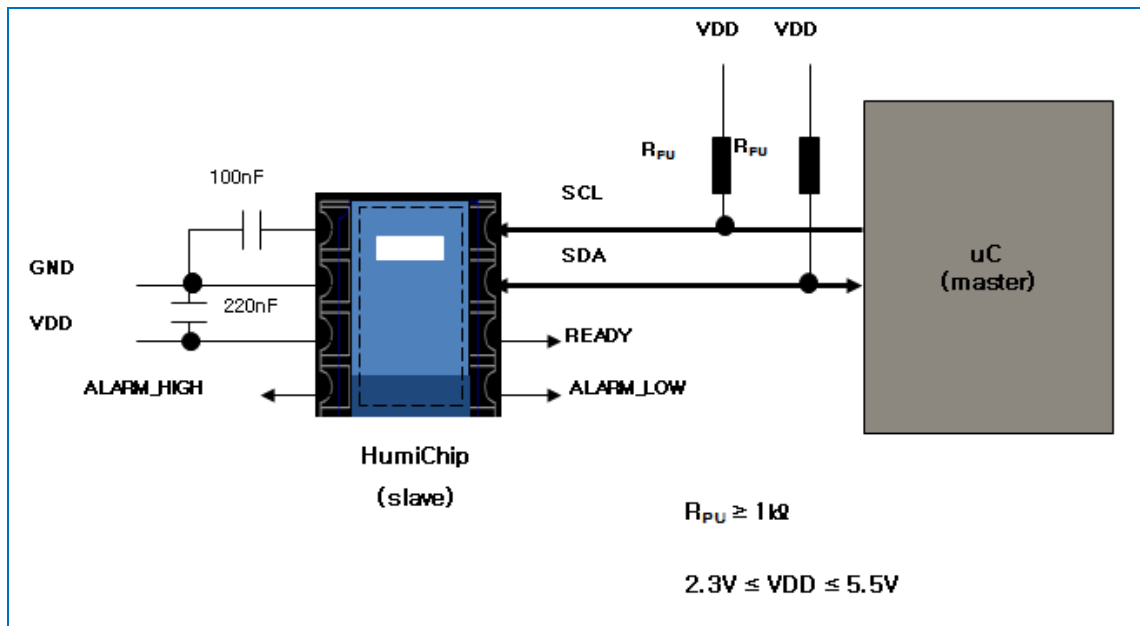

2.2 Analog Output (PDM)

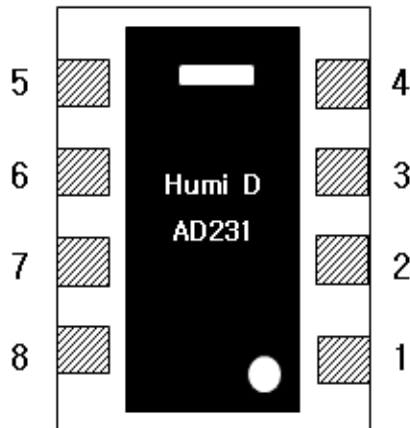

Pin-No	Name	Description
1	PDM_T	Temperature PDM
2	PDM_H	Humidity PDM
3	SDA	I2C data (Not Used)
4	SCL	I2C clock (Not Used)
5	VCORE	Core voltage
6	VSS	Ground supply
7	VDD	Supply voltage (2.3-5.5V)
8	Alarm_High	High Alarm output

2.2.1 Power Pads (5.VCORE, 6.VSS, 7.VDD)

HumiChip® is capable of operating on wide range of power supply voltage from 2.3V to 5.5V.

Recommended supply voltage is either $3.3\pm 0.5V$ or $5.0\pm 0.5V$.

Power supply should be connected to VDD (power

supply pad 7). VDD and VSS (Ground pad 6) should be decoupled with a 220nF capacitor.

Important: Vcore must not be connected to VDD, and it must always be connected to an external 100nF capacitor to ground. (see [Figure 2.2](#))

2.2.2 PDM Output Pads (1.PDM_T, 2.PDM_H)

Temperature PDM (Pulse Density Modulation) appears on the PDM_T / Alarm_Low pad (1) and corrected Humidity PDM appears on the PDM_H pad (2).

When pad (1) is selected for Temperature PDM, Alarm_Low function is disabled and only one Alarm

function (Alarm_High: pad 8) is usable.

Note: **HumiChip®** PDM output is pre-programmed in factory for Humidity and Temperature output mode.

2.2.3 Alarm Pads (8.Alarm_High, 1.Alarm_Low [optional])

As **HumiChip®** PDM is factory set for Humidity and Temperature output mode, only High Alarm output can be used in combination with **HumiChip®** PDM.

If both high and low alarm functions are required, pad 1 and 8 will be programmed at factory to use as

Alarm_Low and Alarm_High respectively with required high and low humidity values. In such case, **HumiChip®** will output corrected humidity PDM only,

See [Section 6](#) for **Alarm function**.

2.2.4 Serial Clock & Data Pads (3.SDA, 4.SCL)

For HumiChip® PDM output, both SDA and SCL

pads are not used and must be connected to VDD.

2.2.5 Typical Circuit Connection

VDD and Ground is decoupled by a 220nF capacitor. Vcore (Not Used) and Ground is also decoupled by a 100nF capacitor. SCL and SDA (not used) are connected to VDD.

Between HumiChip® and MCU (μC), **Low Pass Filtering** (see [Section 5.2](#) for more information) with 10 kΩ resistors and 6,400nF capacitors is added to create an Analog signal.

Figure 2.2 Typical Application Circuit (PDM)

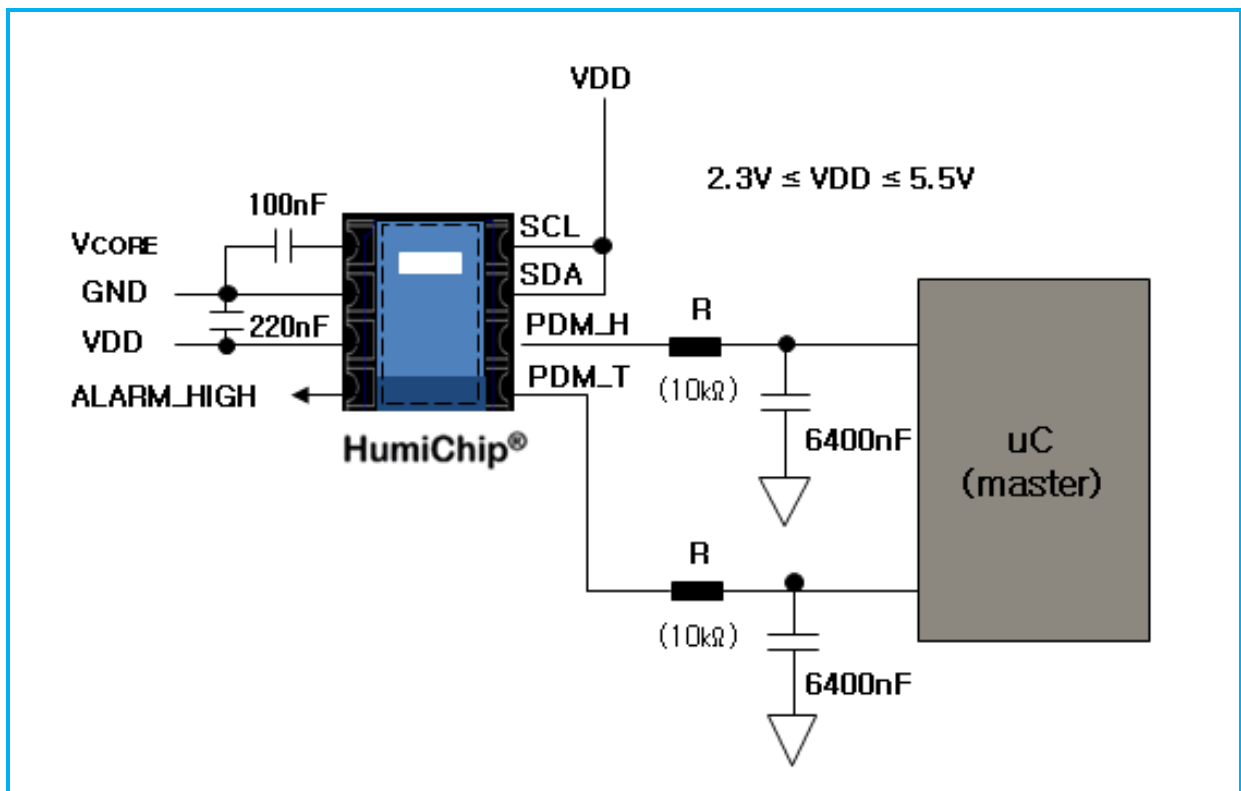

3. Electrical Specification

3.1 Absolute Maximum Rating

[Table 3.1](#) shows the Absolute Maximum Ratings for HumiChip. Exposure to these extreme condition for extended period may deteriorate the sensor

performance and accelerate aging. Functional operation is not implied at these conditions.

3.2 Electrical Specification and Recommended Operating Conditions

The operating conditions recommended for HumiChip is given in [Table 3.2](#) and the electrical specification is shown in [Table 3.3](#).

3.3 Output Pad Drive Strength

Output pad drive strength at different supply voltages and operating temperatures are shown in [Table 3.4](#) and [Table 3.5](#).

3.4 ESD/Latch-Up-Protection

All external module pins have an ESD protection of up to 4000V and a latch-up protection of $\pm 100\text{mA}$ or (up to +8V / down to -4V) relative to VSS/VSSA. The internal module pin V_{CORE} has ESD protection

of up to 2000V. The ESD test follows the Human Body Model with 1.5kOhm/100pF based on MIL 883, Method 3015.7.

[Table 3.1](#) Absolute Maximum Rating

PARAMETER	SYMBOL	MIN	MAX	Unit
Supply Voltage (V _{DD})	V _{DD}	-0.3	6.0	V
Supply Voltage at I/O pads	V _{IO}	-0.3	V _{DD} +0.3	V
Storage Temperature Range	T _{STOR}	-55	150	°C
Junction Temperature	T _j	-55	150	°C

[Table 3.2](#) Recommended Operating Conditions

PARAMETER	SYMBOL	MIN	TYP	MAX	UNIT
-----------	--------	-----	-----	-----	------

Supply Voltage to Gnd	V_{SUPPLY}	2.3		5.5	V
Ambient Temperature Range	T_{AMB}	-40		125	°C
External Capacitance between V_{DD} pin and Gnd	$C_{VSUPPLY}$	100	220	470	nF
External Capacitance between V_{core} and Gnd	$C_{V_{CORE}}$		100		nF
Pull-up on SDA and SCL	R_{PU}	1	2.2		k Ω

Table 3.3 Electrical Characteristics Specifications

PARAMETER	SYMBOL	CONDITIONS	MIN	TYP	MAX	UNITS
SUPPLY						
Supply Current (varies with update rate and output mode)	I_{DD}	At maximum update rate		750	1100	μ A
Extra Current with PDM enabled	I_{PDM}	At maximum update rate		150		μ A
Sleep Mode Current	I_{sleep}	-40 to 85°C		0.6	1	μ A
		-40 to 125°C		1	3	μ A
PDM Output						
Voltage Range	V_{PDM_Range}	3V \pm 10%, 3.3V \pm 10%, 5V \pm 10%	10		90	% V_{SUPPLY}
PDM Frequency	f_{PDM}			$f_{SYS}/8$		KHz
Filter Settling Time ¹	t_{SETT}	0% to 90% LPFilter 10k Ω /400nF			9.2	ms
Ripple ¹	V_{RIPP}	0% to 90% LPFilter 10k Ω /400nF			1.0	mV/V
PDM Additional Error (Including Ratiometricity Error)	E_{PDM}	-40 to 125°C		0.1	0.5	%
DIGITAL I/O						
Voltage Output Level Low	V_{OL}			0	0.2	V_{SUPPLY}
Voltage Output Level High	V_{OH}		0.8	1		V_{SUPPLY}
Voltage Input Level Low	V_{IL}			0	0.2	V_{SUPPLY}
Voltage Input Level High	V_{IH}		0.8	1		V_{SUPPLY}
TOTAL SYSTEM						
Start-Up-Time Power-on (POR) to data ready	t_{STA}	At nominal frequency; fastest and slowest settings	4.25		55	ms
Update Rate(Update Mode)	t_{RESP_UP}	Fastest and slowest settings	0.70		165	ms
Response Time(Sleep Mode)	t_{RESP_SL}	Fastest and slowest settings	1.25		45	ms

Table 3.4 Output High Drive Strength

Output High Drive Strength (mA)						
V _{SUPPLY} (V)	-40°C		25°C		125°C	
	Min	Typ	Min	Typ	Min	Typ
2.3	3.8	6.2	3.3	5.1	2.8	4.2
2.7	7.2	10.5	5.9	8.4	4.7	6.6
3.3	12.1	16.6	9.6	12.9	7.4	10.0
5.5	20.0	20.0	20.0	20.0	20.0	20.0

Table 3.5 Output Low Drive Strength

Output Low Drive Strength (mA)						
V _{SUPPLY} (V)	-40°C		25°C		125°C	
	Min	Typ	Min	Typ	Min	Typ
2.3	10.8	16.0	8.8	12.6	6.9	9.5
2.7	20.0	20.0	16.0	20.0	11.7	14.9
3.3	20.0	20.0	20.0	20.0	18.2	20.0
5.5	20.0	20.0	20.0	20.0	20.0	20.0

4. Communicating with HumiChip®

4.1 Power-On Sequence

On system power-on reset (POR), the **HumiChip®** wakes as an I²C device regardless of the output protocol programmed in EEPROM. After power-on reset, it enters the command window. It then waits for a Start_CM command for 10_{ms} if Fast Startup bit is not set in EEPROM (Factory Setting) or for 3_{ms} if fast startup bit is set in EEPROM (see **Figure 4.1**). If the **HumiChip®** receives the Start_CM command during the command window, it enters and remains in

Command Mode.

Command Mode is primarily used for initializing **HumiChip®**.

If during the power-on sequence, the command window expires without receiving a Start_CM or if the part receives a Start_NOM command in Command Mode, the device will immediately assume its programmed output mode and will perform one complete measurement cycle

4.2 I²C Features and Timing

The HumiChip® uses I²C-compatible communication protocol with support for 20kHz to 400kHz bit rates. The I²C slave address (0x00 to 0x7F) is selected by the Device_ID bits in the Cust_Config EEPROM word (see **Table 6.1** for bit assignments).

See **Figure 4.2** for I²C Timing Diagram and **Table 4.1** for definitions of the parameters shown in the diagram.

Note: Detailed Timing Chart and Reference Programming Code are available upon request.

Figure 4.1 Power-On Sequence with Fast Start-up Bit Set in EEPROM

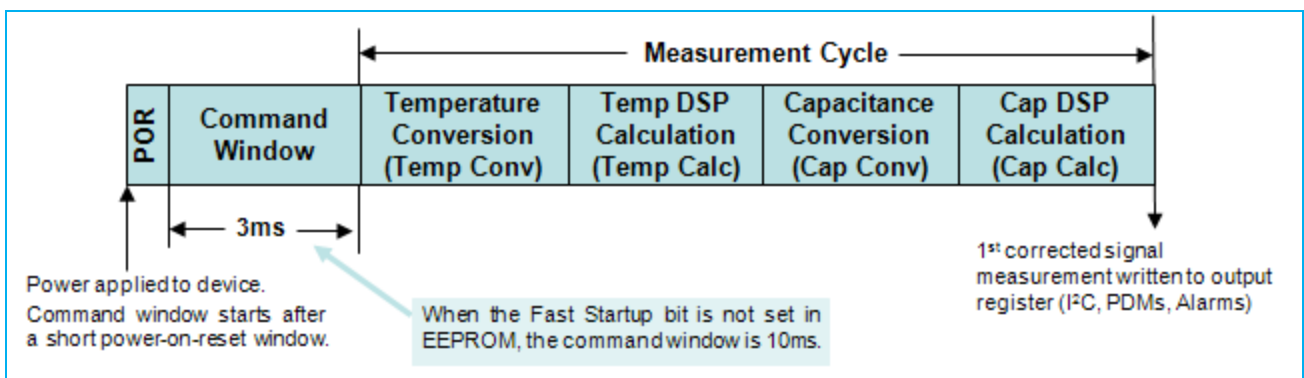

Figure 4.2 I²C Timing Diagram

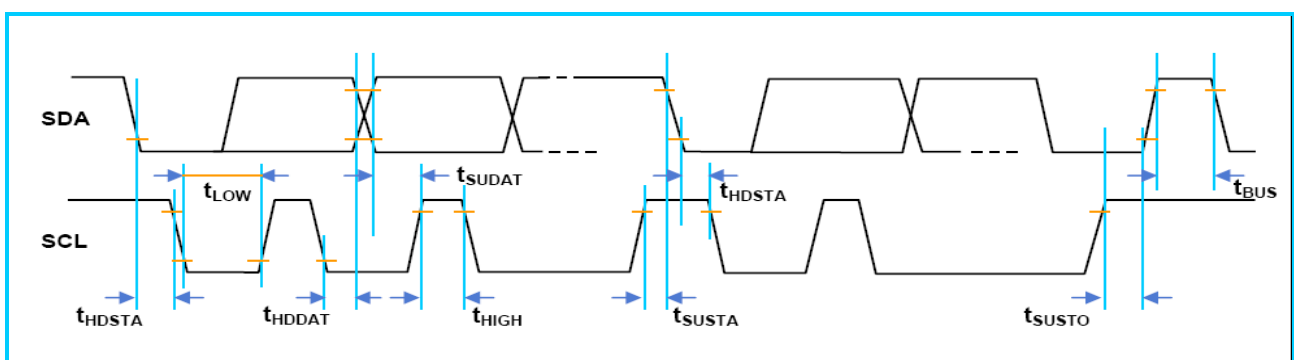

Table 4.1 I²C Parameters

PARAMETER	SYMBOL	MIN	TYP	MAX	UNITS
SCL clock frequency	f _{SCL}	20		400	kHz
Start condition hold time relative to SCL edge	t _{HDSTA}	0.1			μs

Minimum SCL clock low width ¹	t_{LOW}	0.6			μS
Minimum SCL clock high width ¹	t_{HIGH}	0.6			μS
Start condition setup time relative to SCL edge	t_{SUSTA}	0.1			μS
Data hold time on SDA relative to SCL edge	t_{HDDAT}	0		0.5	μS
Data setup time on SDA relative to SCL edge	t_{SUDAT}	0.1			μS
Stop condition setup time on SCL	t_{SUSTO}	0.1			μS
Bus free time between stop condition and start condition	t_{BUS}	1			μS

1. Combined low and high widths must equal or exceed minimum SCL period

4.3 Measurement Modes

The **HumiChip**[®] can be programmed to operate in either Sleep Mode or Update Mode. The measurement mode is selected with the Measurement_Mode bit in the **HumiChip**[®] Config

Register word. In Sleep Mode, the part waits for commands from the master before taking measurements (see **section 4.3.2**).

4.3.1 Data Fetch in Update Mode

In Update Mode, I²C is used to fetch data from the digital output register using a Data Fetch (DF) command.

regarding the status bits). As shown in **Figure 4.3.1** after a measurement cycle is complete, valid data can be fetched. If the next data fetch is performed too early, the data will be the same as the previous fetch with stale status bits. As shown in **Figure 4.3.1**, a rise on the Ready pin can also be used to tell when valid data is ready to be fetched.

Detecting when data is ready to be fetched can be handled either by polling or by monitoring the Ready pin (see section 4.8 for details on the Ready pin). The status bits of a DF tell whether or not the data is valid or stale (see **Table 4.2**

Figure 4.3.1 I²C Data Fetching in Update Mode

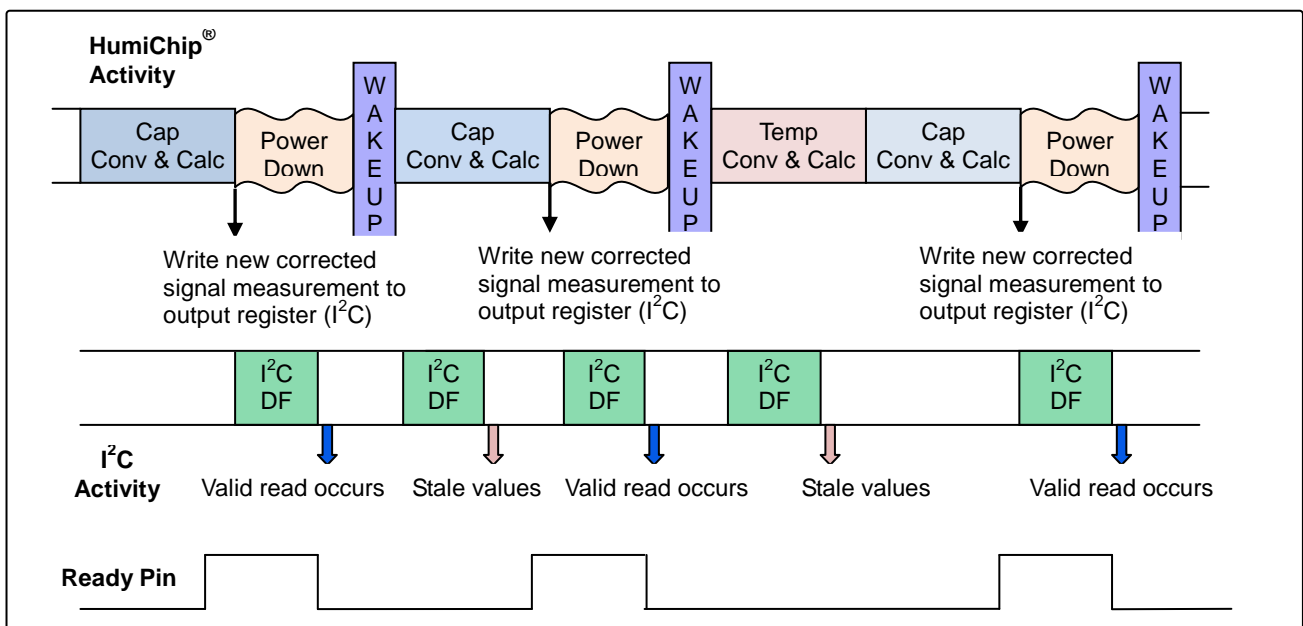

4.3.2 Data Fetch in Sleep Mode

In Sleep Mode, the **HumiChip®** core will only perform conversions when **HumiChip®** receives a Measurement Request command (MR); otherwise, the **HumiChip®** is always powered down. Measurement Request commands can only be sent using I²C, so Sleep Mode is **not available for PDM**. The Alarms can be used in Sleep Mode but only in combination with I²C.

Note: Sleep Mode power consumption is significantly lower than Update Mode power consumption (see [Table 3.3](#) for exact values).

Figure 4.3.2 shows the measurement and communication sequence for Sleep Mode. The master sends an MR command to wake the

HumiChip® from power down. After **HumiChip®** wakes up, a measurement cycle is performed consisting of both a temperature and a capacitance conversion followed by the **HumiChip®** Core correction calculations.

At the end of a measurement cycle, the digital output register and Alarms will be updated before powering down. An I²C data fetch (DF) is performed during the power-down period to fetch the data from the output register. In I²C the user can send another MR to start a new measurement cycle without fetching the previous data. After the data has been fetched, the **HumiChip®** remains powered down until the master sends an MR command.

Figure 4.3.2 Measurement Sequence in Sleep Mode

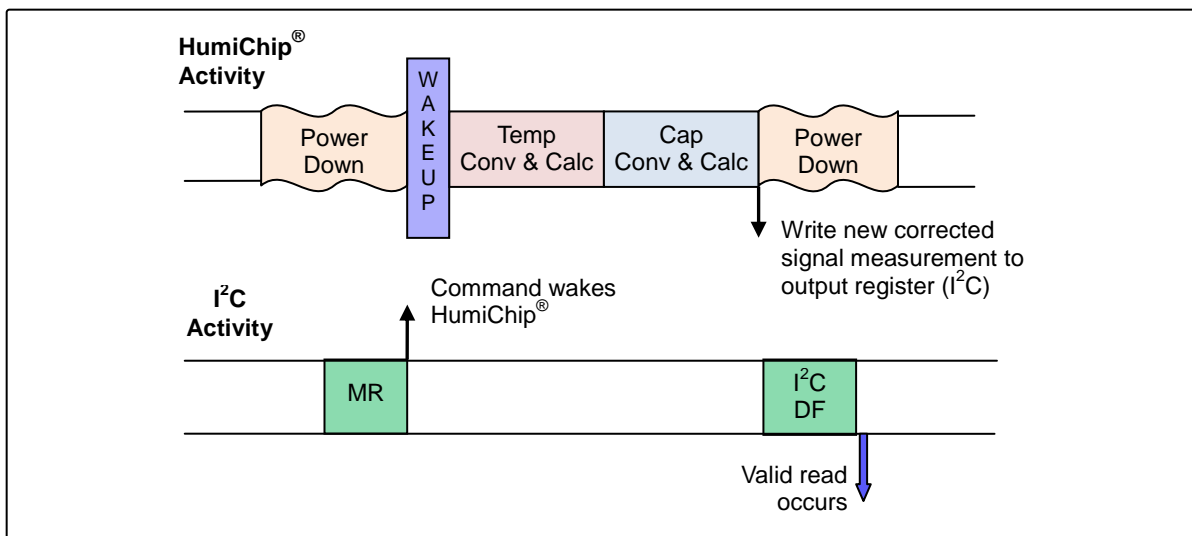
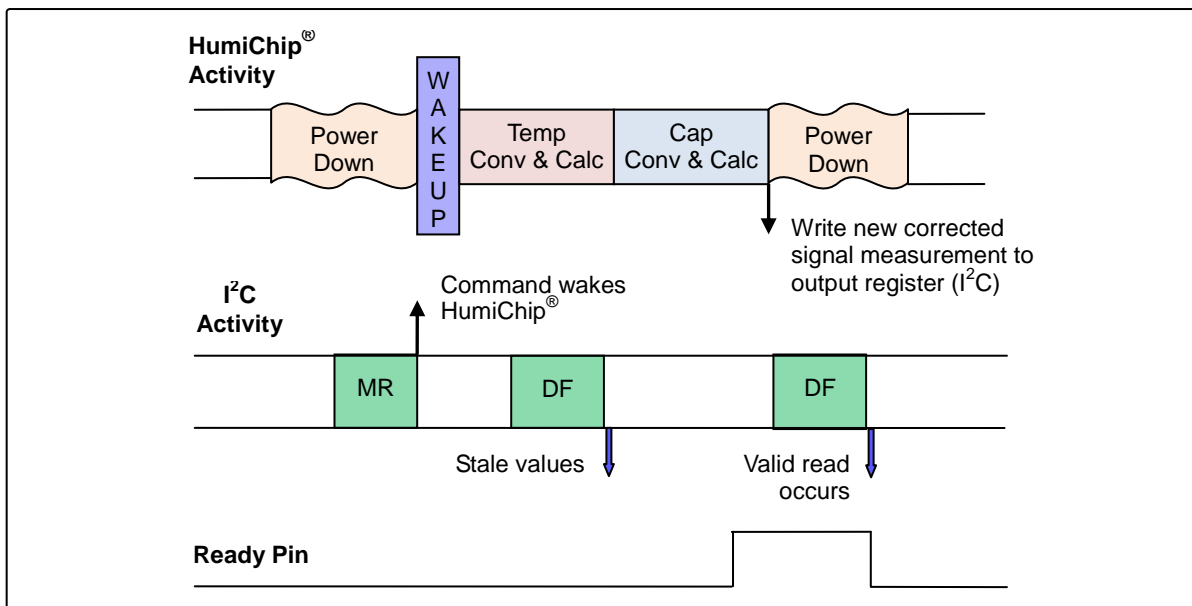

Figure 4.3.3 I²C Data Fetching in Sleep Mode



In Sleep Mode, I2C are used to request a measurement with a MR command and to fetch data from the digital output register using a Data Fetch (DF) command (see **section 4.7** for details on the MR command).

Detecting when data is ready to be fetched can be handled either by polling or by monitoring the Ready pin (see **section 4.8** for details on the

Ready pin). The status bits of a DF tell whether the data is valid or stale (see **section 4.4** regarding the status bits). As shown in **Figure 4.3.3** after a measurement cycle is complete, valid data can be fetched. If the next data fetch is performed too early, the data will be the same as the previous fetch with stale status bits. As shown in **Figure 4.3.3** a rise on the Ready pin can also be used to tell when valid data is ready to be fetched.

4.4 Status Bits

Status bits (the two MSBs of the fetched high data byte, see **Table 4.2**) are provided in I²C but not in

PDM. The status bits are used to indicate the current state of the fetched data.

Table 4.2 Status Bits

Status Bits(I ² C)	PDM Output	Definition
00 _B	Clipped normal output	Valid data: Data that has not been fetched since the last measurement cycle.
01 _B	Not applicable	Stale data: Data that has already been fetched since the last measurement cycle.
10 _B	Not applicable	Command Mode: The HumiChip [®] is in Command Mode.
11 _B	Not used	Not used

4.5 I²C Commands

As detailed in **Table 4.3**, there are two types of commands which allow the user to interface with

the **HumiChip**[®] in the I²C.

Table 4.3 I²C Command Bits

Type	Description	Communication Supported	Reference Sections
Data Fetch (DF)	Used to fetch data in any digital mode	I ² C	Section 4.6
Measurement Request (MR)	Used to start measurements in Sleep Mode	I ² C	Section 4.7

4.6 Data Fetch (DF)

The Data Fetch (DF) command is used to fetch data in any digital output mode.

An I²C Data Fetch command starts with the 7-bit slave address and the 8th bit = 1 (READ).

The **HumiChip**[®] as the slave sends an acknowledgement (ACK) indicating success. The number of data bytes returned by the **HumiChip**[®] is determined by when the master sends the NACK and stop condition. [Figure 4.3](#) shows examples of fetching two, three and four bytes respectively.

The full 14 bits of humidity data are fetched in the first two bytes. The MSBs of the first byte are the

status bits.

If temperature data is needed, additional temperature bytes can be fetched. In [Figure 4.3](#), the three-byte data fetch returns 1 byte of temperature data (8-bit accuracy) after the humidity data. A fourth byte can be fetched where the six MSBs of the fetched byte are the six LSBs of a 14-bit temperature measurement. The last two bits of the fourth byte are undetermined and should be masked off in the application.

Figure 4.3 I²C Measurement Packet Reads

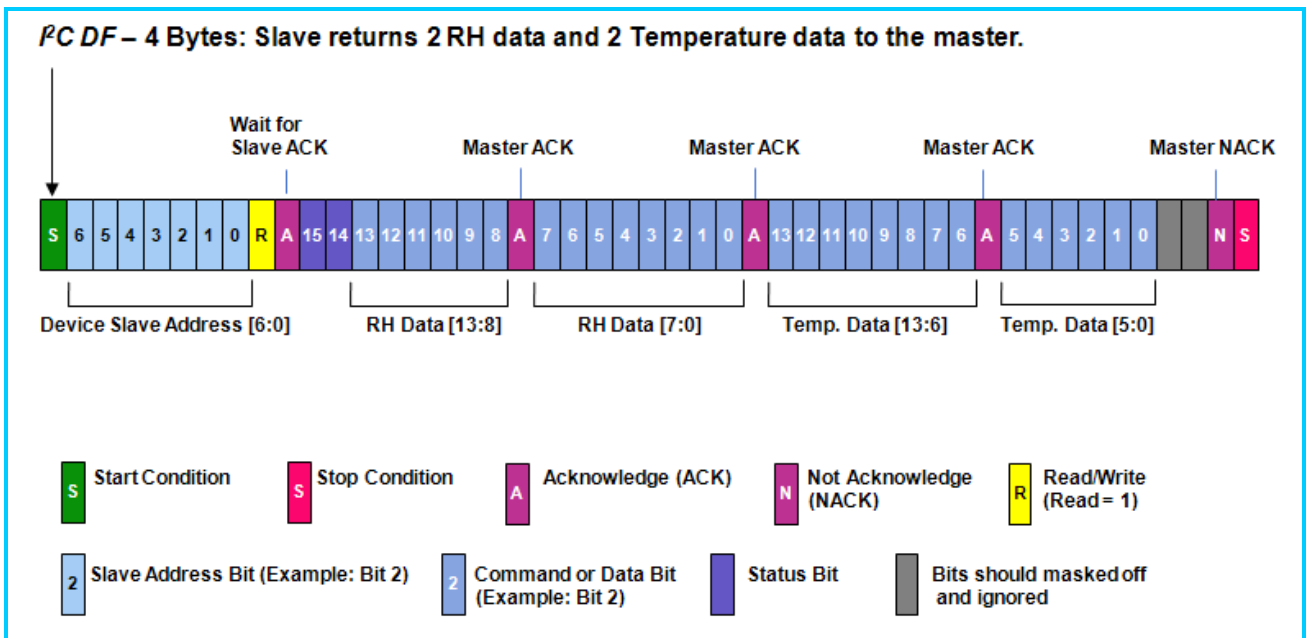
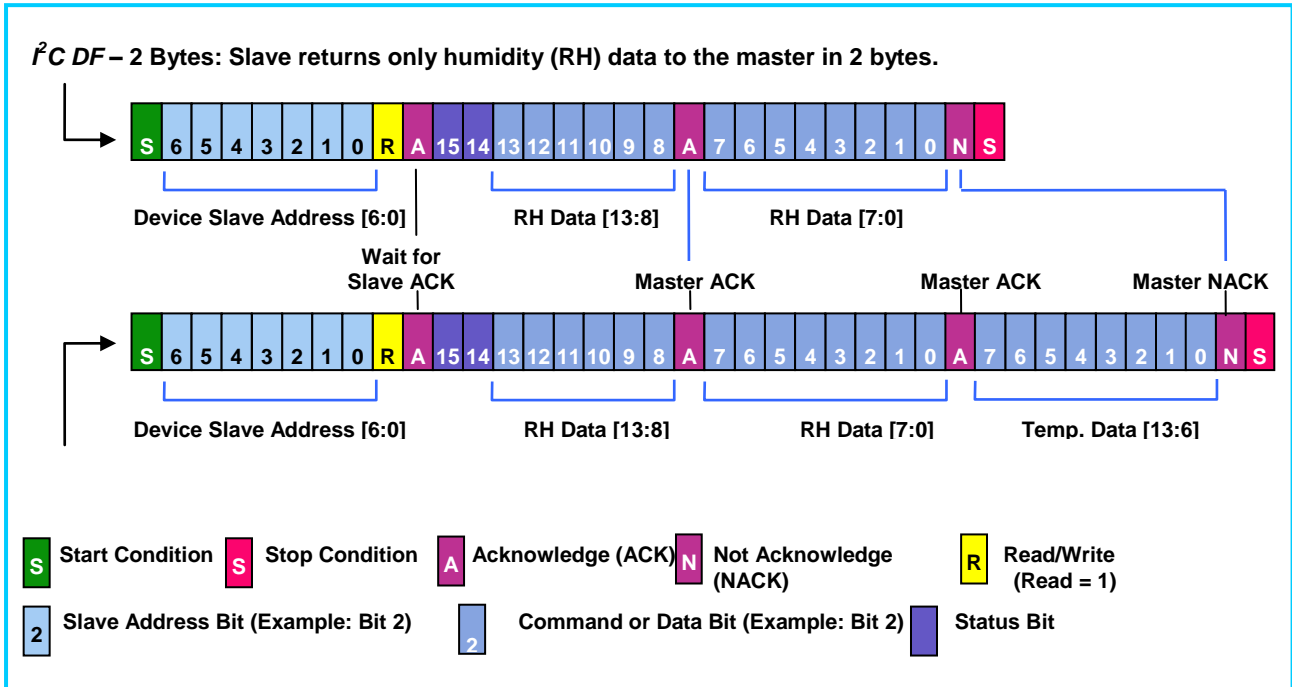

Humidity & Temperature Conversion Formula

Humidity Output (%RH)	$(RH_High [5:0] \times 256 + RH_Low [7:0]) / 2^{14} \times 100$
Temperature Output (°C)	$(Temp_High [7:0] \times 64 + Temp_Low [7:2] / 4) / 2^{14} \times 165 - 40$

4.7 Measurement Request (MR)

A measurement request (MR) is a Sleep-Mode-only command sent by the master to wake up the **HumiChip®** and start a new measurement cycle in I²C.

The I²C MR is used to wake up the device in Sleep Mode and start a complete measurement cycle starting with a temperature measurement, followed by a humidity measurement, and then the results can be fetched by master with I²C.

As shown in **Figure 4.4**, the communication contains only the slave address and the WRITE bit (0) sent by the master.

After the **HumiChip®** responds with the slave ACK, the master creates a stop condition.

Note: The I²C MR function can also be accomplished by sending “don’t care” data after the address instead of immediately sending a stop bit.

Figure 4.4 I²C Measurement Request

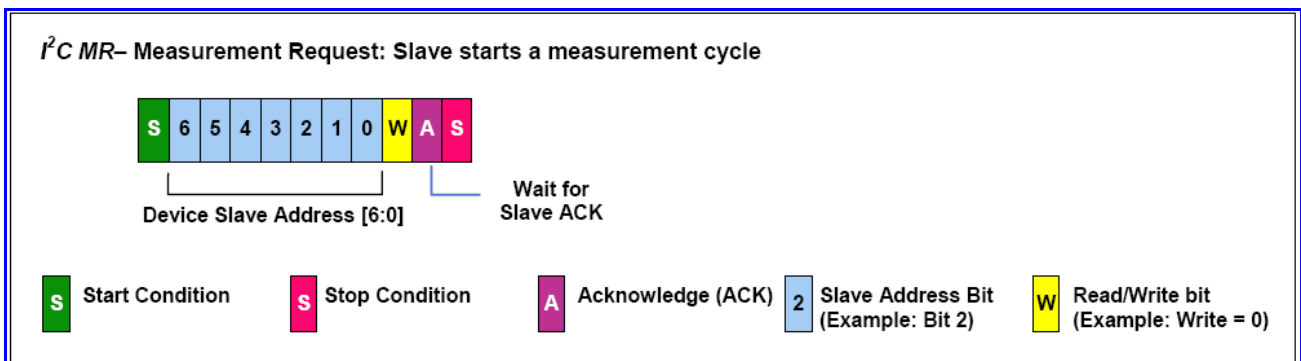

4.8 Ready Pin

A rise on the Ready pin indicates that new data is ready to be fetched from the I²C interface. The Ready pin stays high until a Data Fetch (DF) command is sent; it stays high even if additional measurements are performed before the DF.

The Ready pin’s output driver type is selectable as either full push-pull or open drain using the **Note:** If two high alarms or two low alarms are

Ready_Open_Drain bit in EEPROM word Cust_Config (see **Table 6.1** for bit assignments and settings). Point-to-point communication most likely uses the full push-pull driver. If an application requires interfacing to multiple parts, then the open drain option can allow for just one wire and one pull-up resistor to connect all the parts in a bus format.

4.9 Command Mode

Command Mode commands are only supported for the I²C protocol. As shown in **Figure 4.5**, commands are 4-byte packets with the first byte being a 7-bit

slave address followed by 0 for write. The second byte is the command byte and the last two bytes form a 16-bit data field.

Figure 4.5 I²C Command Format

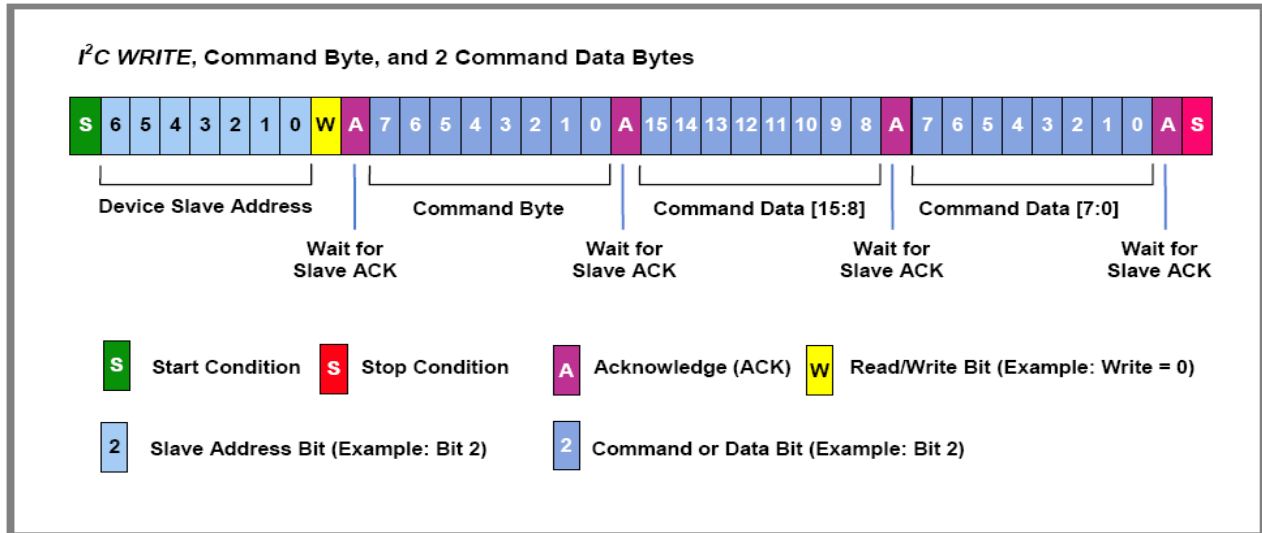

4.10 Command Encodings

[Table 4.4](#) describes all the commands that are offered in Command Mode.

Note: Only the commands listed in [Table 4.4](#) are valid. Other encodings might cause unpredictable results. If data is not needed for the command, zeros must be supplied as data to complete the 4-byte packet.

Table 4.4 Command List and Encodings

Command Byte 8 Command Bits (Hex)	Third and Fourth Bytes 16 Data Bits(Hex)	Description	Response Time
0x16 to 0x1F	0x0000	EEPROM Read of addresses 0x16 to 0x1F After this command has been sent and executed, a data fetch must be performed.	100µs
0x56 to 0x5F	0xYYYY (Y = data)	Write to EEPROM addresses 0x16 to 0x1F The 2 bytes of data sent will be written to the address specified in the 6 LSBs of the command byte.	12ms
0x80	0x0000	Start_NOM Ends Command Mode and transitions to Normal Operation Mode.	
0xA0	0x0000	Start_CM Start Command Mode: used to enter the command interpreting mode. Start_CM is only valid during the power-on command window.	100µs

4.11 Command Response and Data Fetch

After a command has been sent and the execution time defined in [Table 4.4](#) has expired, an I²C Data Fetch (DF) can be performed to fetch the response. As shown in [Figure 4.6](#), after the slave address has been sent, the first byte fetched is the response byte.

The upper two status bits will always be 10_B to represent Command Mode. The lower two bits are the response bits. [Table 4.5](#) describes the different responses that can be fetched. To determine if a command has finished executing, poll the part until a Busy response is no longer received. The middle four bits of the response byte are command diagnostic bits where each bit represents a different diagnostic (see [Table 4.6](#)).

Note: Regardless of what the response bits are, one or more of the diagnostic bits may be set indicating an error occurred during the execution of the command.

Note: Only one command can be executed at a

time. After a command is sent another command must not be sent until the execution time of the first command defined in [Table 4.4](#) has expired.

For all commands except EEPROM Read, the data fetch should be terminated after the response byte is read. If the command was an EEPROM Read, then the user will fetch two more bytes as shown in [Figure 4.6](#), example 3. If a Corrected EEPROM Error diagnostic was flagged after an EEPROM read, the user has the option to write this data back to attempt to fix the error. Instead of polling to determine if a command has finished executing, the user can use the Ready pin. In this case, wait for the Ready pin to rise, which indicates that the command has executed. Then a data fetch can be performed to get the response and data (see [Figure 4.6](#))

[Table 4.5](#) Response Bits

Encoding	Name	Description
00 _B	Busy	The command is busy executing.
01 _B	Positive Acknowledge	The command executed successfully.
10 _B	Negative Acknowledge	The command was not recognized or an EEPROM write was attempted while the EEPROM was locked.

[Table 4.6](#) Command Diagnostic Bits

Bit Position	Name	Description
2	Corrected EEPROM Error	A corrected EEPROM error occurred in execution of the last command.
3	Uncorrectable EEPROM Error	An uncorrectable EEPROM error occurred in execution of the last command.
4	RAM Parity Error	A RAM parity error occurred during a microcontroller instruction in the execution of the last command.
5	Configuration Error	An EEPROM or RAM parity error occurred in the initial loading of the configuration registers.

Figure 4.6 Command Mode Data Fetch

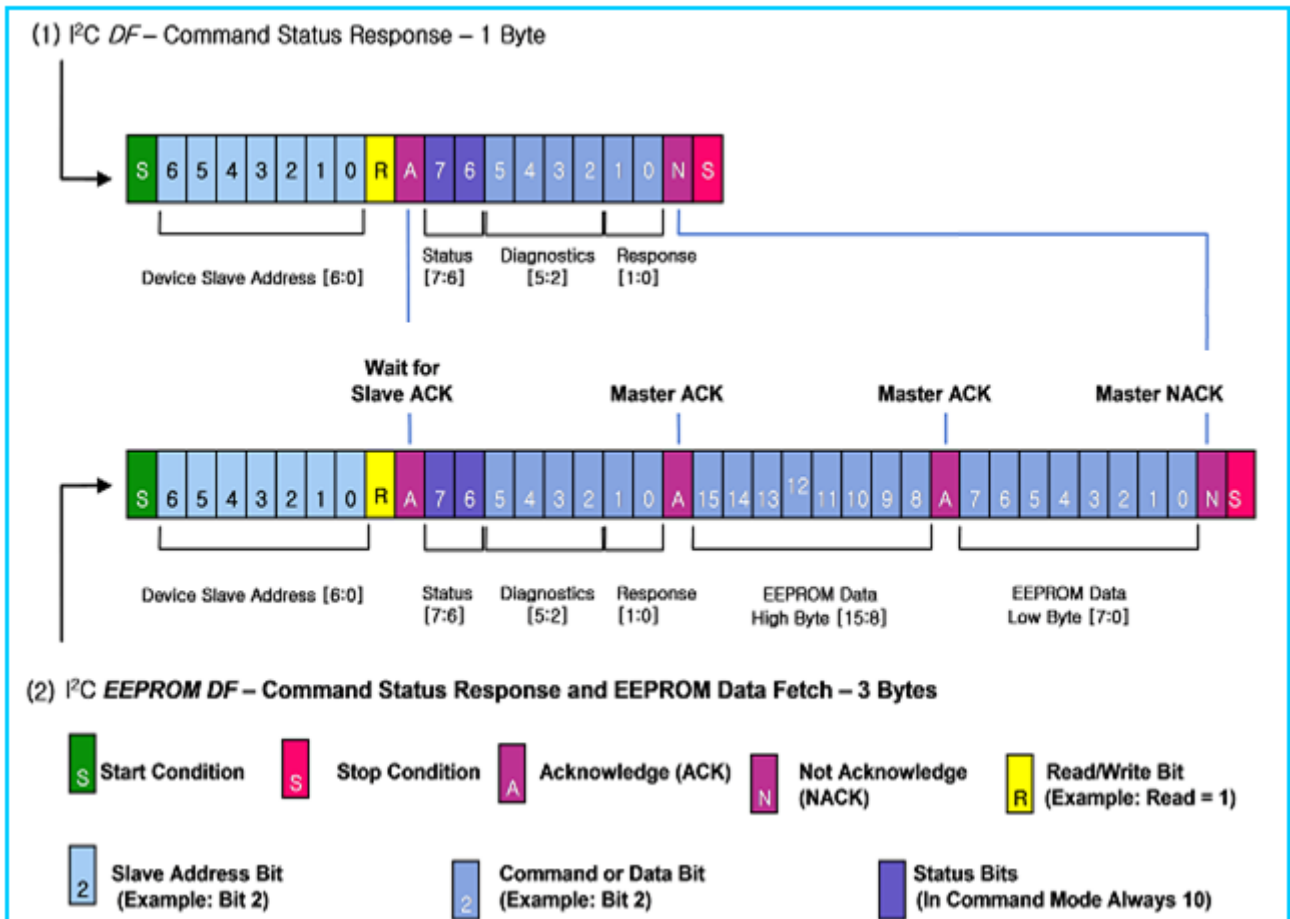

4.12 EEPROM

The EEPROM array contains the calibration coefficients for gain and offset, etc., and the configuration bits for the analog front end, output modes, measurement modes, etc. The **HumiChip**[®] EEPROM is arranged as 10 16-bit words (see [Table 4.7](#)).

See section **4.9 Command Mode** for instructions on reading and writing to the EEPROM in Command Mode via the I²C interface. When programming the EEPROM, an internal charge pump voltage is used; therefore a high voltage supply is not needed.

Table 4.7 EEPROM Word Assignments

EEPROM Word	Bit Range	IC Default	Name	Description and Notes
16 _{HEX}	13:0	0x3FFF	PDM_Clip_High	PDM high clipping limit
17 _{HEX}	13:0	0x0000	PDM_Clip_Low	PDM low clipping limit
18 _{HEX}	13:0	0x3FFF	Alarm_High_On	High alarm on trip point
19 _{HEX}	13:0	0x3FFF	Alarm_High_Off	High alarm off trip point
1A _{HEX}	13:0	0x0000	Alarm_Low_On	Low alarm on trip point
1B _{HEX}	13:0	0x0000	Alarm_Low_Off	Low alarm off trip point
1C _{HEX}	15:0	0x0028	Cust_Config	Customer Configuration (see Table 6.1)
1D _{HEX}	15:0	0x0000	Reserved	Reserved Word: Do Not Change ; must leave at factory settings
1E _{HEX}	15:0	0x0000	Cust_ID2	Customer ID byte 2: For use by customer
1F _{HEX}	15:0	0x0000	Cust_ID3	Customer ID byte 3: For use by customer

5. Converting PDM to Analog Signal

5.1 PDM (Pulse Density Modulation)

Both corrected humidity and temperature are available in PDM output. Humidity PDM appears on PDM_H (2) pad and Temperature PDM appears on the PDM_T (1) pad.

The PDM frequency is $231.25\text{kHz} \pm 15\%$ (i.e., the oscillator frequency $1.85\text{MHz} \pm 15\%$ divided by 8). Both PDMs output 14-bit values for Humidity and

Temperature.

In PDM Mode, **HumiChip**[®] is programmed to Update Mode. Every time a conversion cycle has finished, the PDM will begin outputting the new value.

See [Figure 5.1](#) for PDM Timing Diagram.

Figure 5.1 PDM Signal Timing Diagram

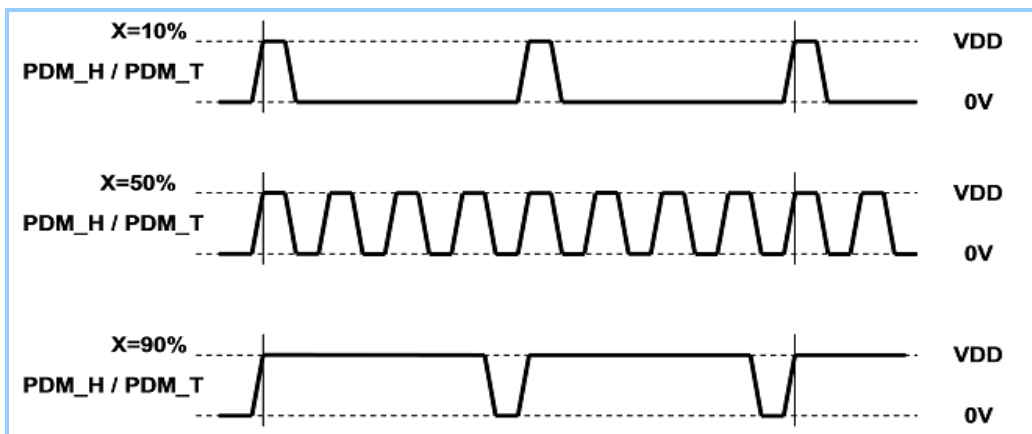

5.2 Low Pass Filtering

An analog output value is created by low-pass filtering the PDM output; a simple first-order RC filter will work in this application.

Select the time constant of the filter based on the requirements for setting time and/or peak-to-peak ripple.

Important: The resistor of the RC filter must be $\geq 10\text{k}\Omega$.

Table 5.1 Low Pass Filter Example for $R=10\text{k}\Omega$

Filter Capacitance (nF)	PDM_H / PDM_T		Desired Analog Output Resolution
	Vpp Ripple (mV/V)	0 to 90% settling time (ms)	
100	4.3	2.3	8
400	1.0	9.2	10
1600	0.3	36.8	12
6400	0.1	147.2	14

For different (higher) resistor, the normalized ripple $VPP(mV/V)$ can be calculated as

$$VPP(mV / V) = 4324 / [R(k\Omega) * C(nF)]$$

Or the setting time t_{SETT} for a 0% to 90% setting can be calculated as

$$t_{SETT} (ms) = 0.0023 * R(k\Omega) * C(nF)$$

5.3 Analog Output Characteristics

5.3.1 Polynomial Equation Humidity

$$PDM_H [mV] = \%RH / 100 * VDD[mV]$$

5.3.2 Polynomial Equation Temperature

$$PDM_T [mV] = ((T[^\circ C] / 165) + 0.2424) * VDD[mV]$$

6. Alarm Function (Optional)

6.1 Alarm Output

The alarm output can be used to monitor whether Humidity reading has exceeded or fallen below pre-programmed values. The alarm can be used to drive an open-drain load connected to VDD as shown in [Figure 6.3](#) or it can function as a full push-pull driver.

If a high voltage application is required, external devices can be controlled with the Alarm pads, as demonstrated in [Figure 6.1](#) and [Figure 6.2](#).

In standard **HumiChip**[®] PDM mode, only the High Alarm can be used.

6.2 Alarm Registers

Four registers are associated with the alarm functions: Alarm_High_On, Alarm_High_Off, Alarm_Low_On, and Alarm_Low_Off (see [Table 4.7](#)). Each of these four registers is a 14-bit value that determines where the alarms turn on or off. The two high alarm registers form the output with hysteresis for the Alarm_High pin, and the two low alarm registers form the output with hysteresis for

the Alarm_Low pin. Each of the two alarm pins can be configured independently using Alarm_Low_Cfg and Alarm_High_Cfg located in EEPROM word Cust_Config (see [Table 6.1](#) for bit assignments).

Note: If two high alarms or two low alarms are needed, see [section 6.5 Alarm Polarity](#).

6.3 Alarm Operation

As shown in [Figure 6.4](#) the Alarm_High_On register determines where the high alarm trip point is and the Alarm_High_Off register determines where the high alarm turns off if the high alarm has been activated. The high alarm hysteresis value is equal to Alarm_High_On – Alarm_High_Off. The same is

true for the low alarm where Alarm_Low_On is the low alarm trip point with Alarm_Low_Off determining the alarm shut off point. The low alarm hysteresis value is equal to Alarm_Low_Off – Alarm_Low_On. [Figure 6.5](#) shows output operation flowcharts for both the Alarm_High and Alarm_Low pins.

6.4 Alarm Output Configuration

The user can select the output driver configuration for each alarm using the Output Configuration bit in the Alarm_High_Cfg and Alarm_Low_Cfg registers in EEPROM word Cust_Config (see [Table 6.1](#) for bit assignments). For applications, such as interfacing with a microcontroller or controlling an external device, select the full push-pull driver for the alarm output type. For an application that directly drives a

load connected to VDD, the typical selection is the open-drain output type. An advantage of making an alarm output open drain is that in a system with multiple devices, the alarm outputs of each **HumiChip**[®] can be connected together with a single pull-up resistance so that one can detect an alarm on any device with a single wire.

6.5 Alarm Polarity

For both alarm pins, the polarity of the alarm output is selected using the Alarm Polarity bit in the Alarm_High_Cfg and Alarm_Low_Cfg registers in EEPROM word Cust_Config (see [Table 6.1](#) for bit assignments). Another feature of the polarity bits is the ability to create two high alarms or two low alarms. For example, with applications requiring two high alarms, flip the polarity bit of the Alarm_Low pin, and it will act as a high alarm. However, in this case, the effect of the alarm low registers is also changed: the Alarm_Low_On

register would act like the Alarm_High_Off register and the Alarm_Low_Off register would act like the Alarm_High_On register. The same can be done to achieve two low alarms: the Alarm_High pin would have the polarity bit flipped, and the two Alarm_High registers would have opposite meanings.

Figure 6.1 Bang-Bang Humidity Control (High Voltage Application)

HumiChip® PDM: 1 Alarms / Humidity Output (Optional)

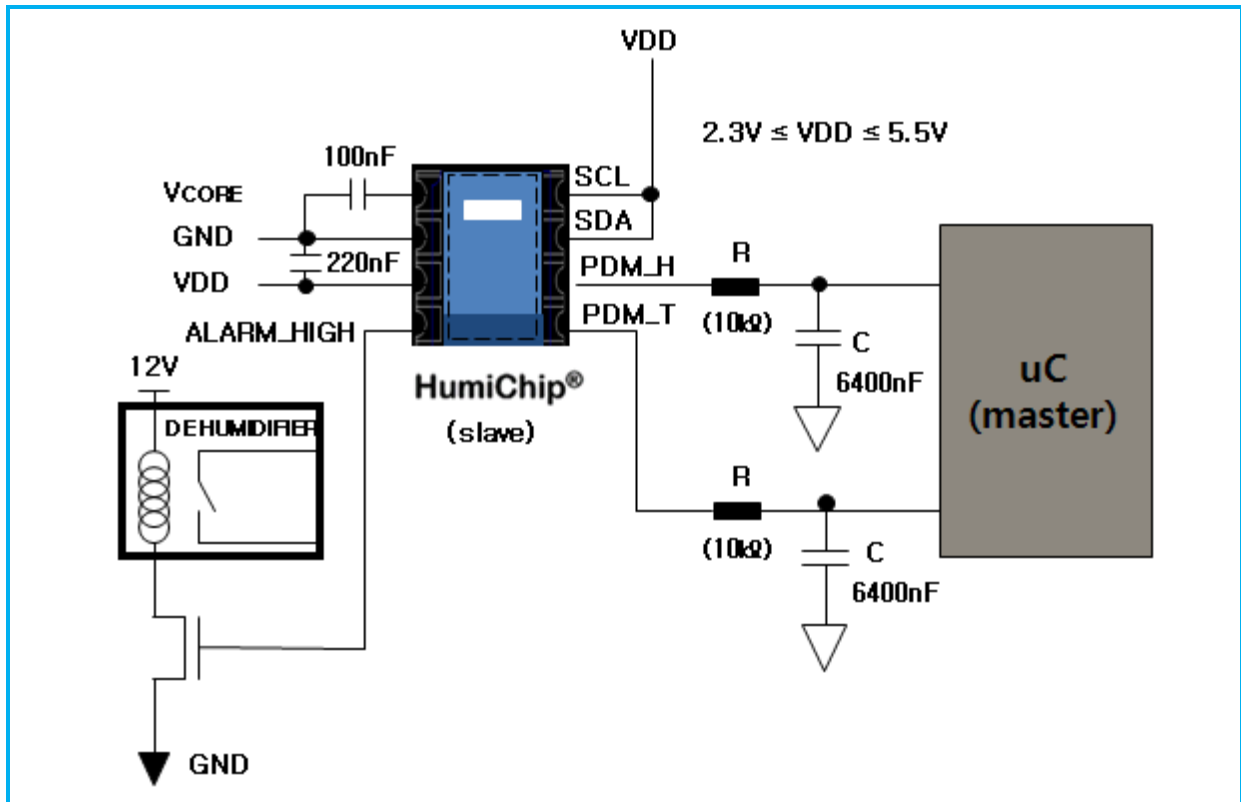

Figure 6.2 Bang-Bang Humidity Control (High Voltage Application)

HumiChip® I2C : 2 Alarms / Humidity Output (Optional)

HumiChip® also can be directly installed to a device without MCU interface when only a switch on/off function is required at desired humidity level. (e.g. Bathroom Vent Fan, Humidifiers, Dehumidifiers)

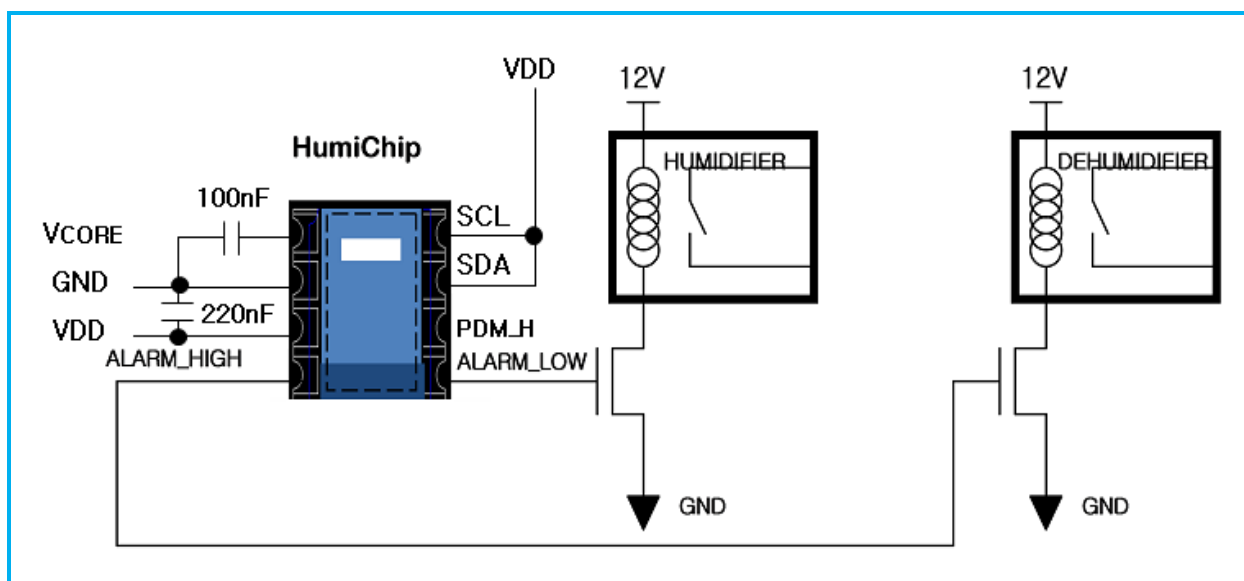

Figure 6.3 LED control with Alarm function

HumiChip® PDM: 1 Alarms / Humidity Output (Optional)

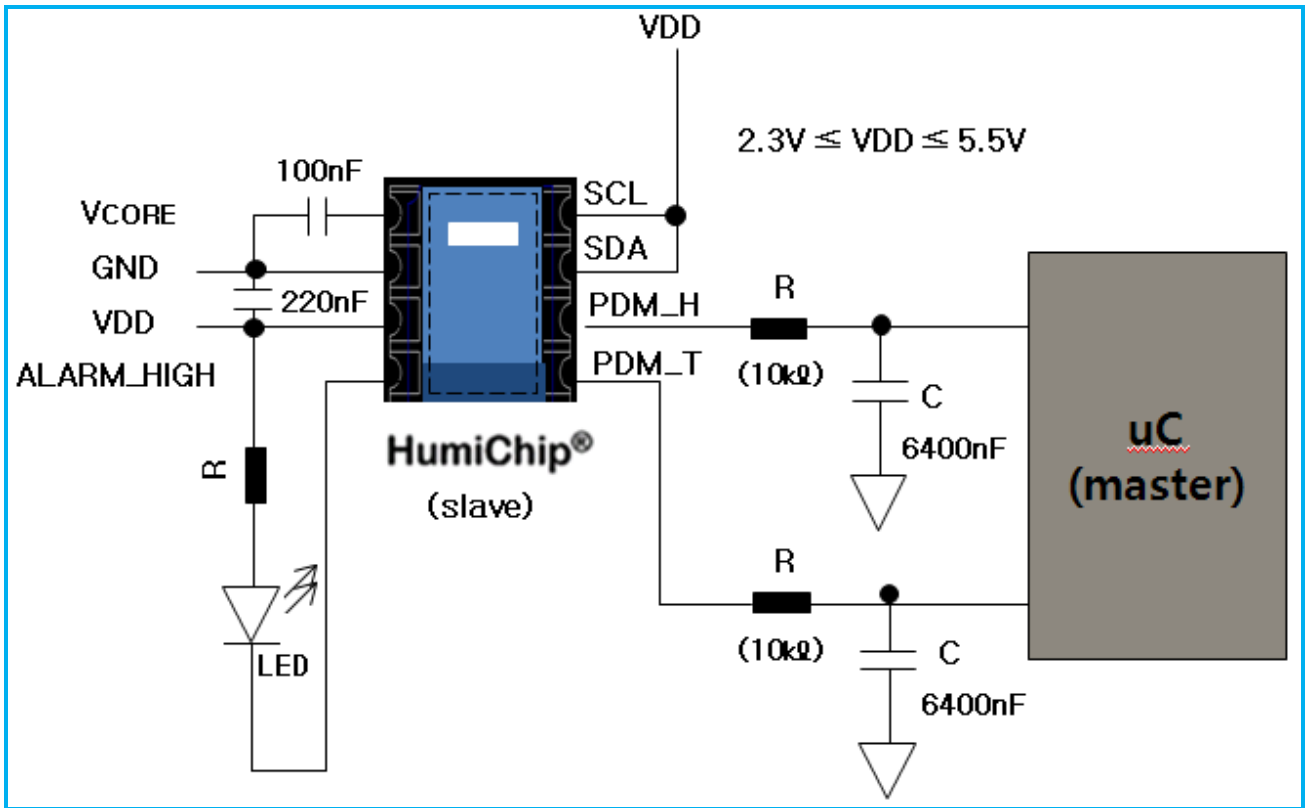

Figure 6.4 Example of Alarm Function

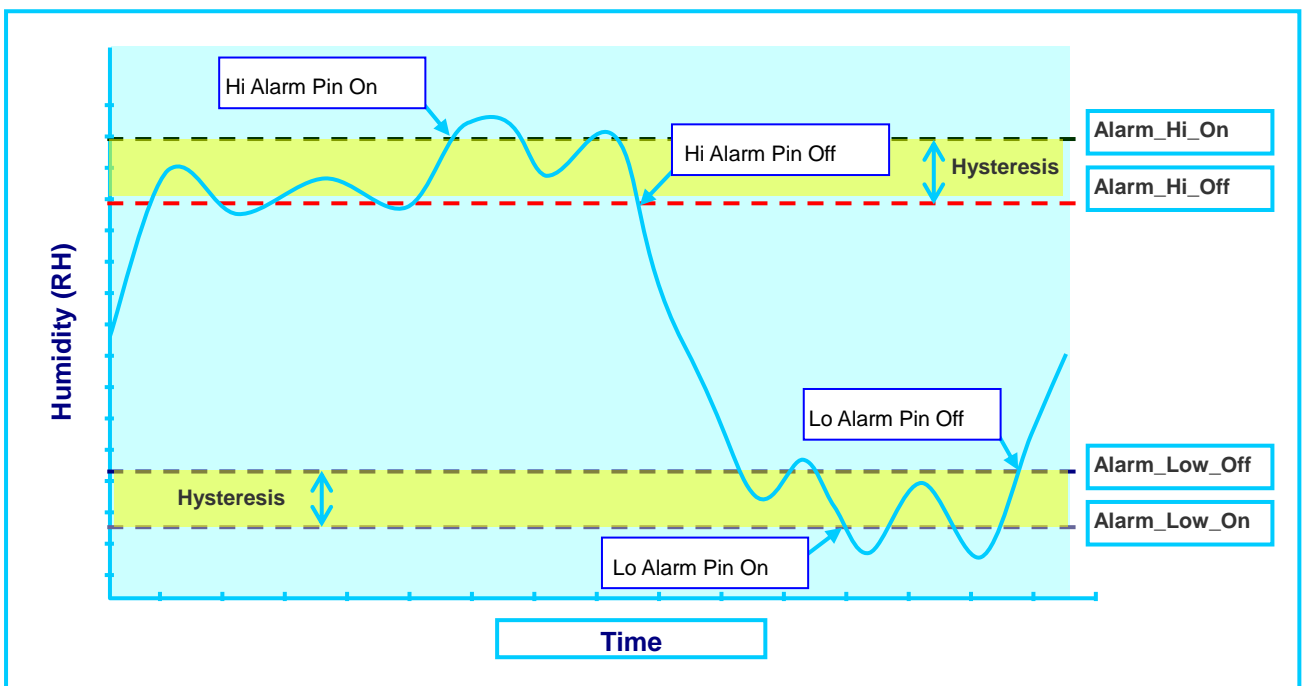

Figure 6.5 Alarm Output Flow Chart

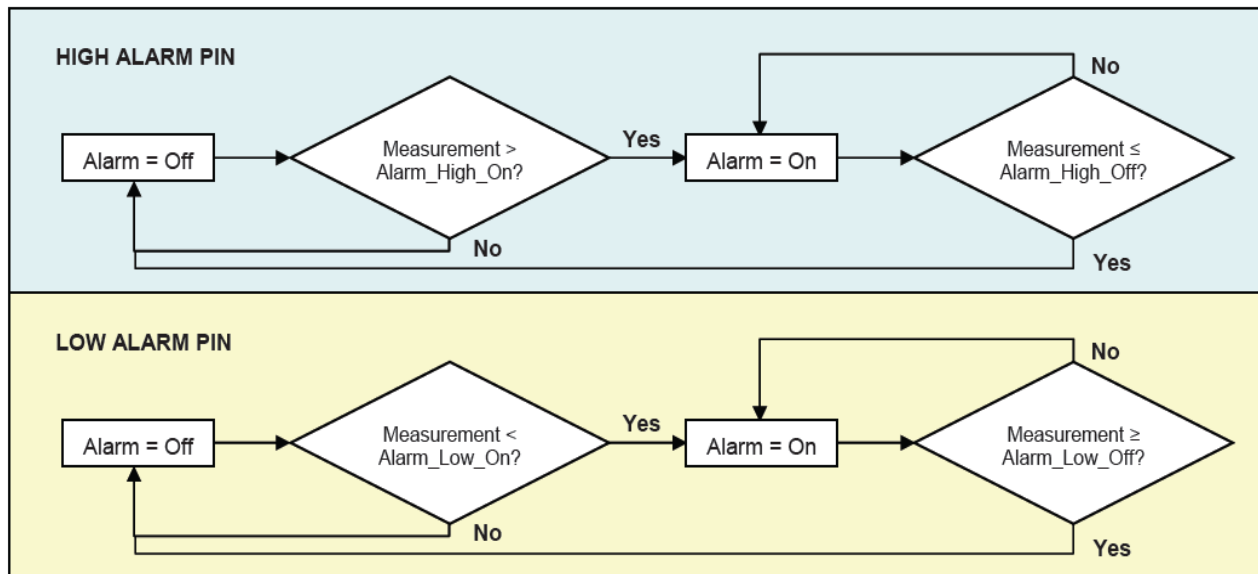

Table 6.1 Cust_Config Bit Assignments

Bit Range	IC Default	Name	Description and Notes						
6:0	0101000	Device_ID	I ² C slave address						
8:7	00	Alarm_Low_Cfg	Configure the Alarm_Low output pin: <table border="1"> <thead> <tr> <th>Bits</th> <th>Description</th> </tr> </thead> <tbody> <tr> <td>7</td> <td>Alarm Polarity: 0 = Active High 1 = Active Low</td> </tr> <tr> <td>8</td> <td>Output Configuration: 0 = Full push-pull 1 = Open drain</td> </tr> </tbody> </table>	Bits	Description	7	Alarm Polarity: 0 = Active High 1 = Active Low	8	Output Configuration: 0 = Full push-pull 1 = Open drain
Bits	Description								
7	Alarm Polarity: 0 = Active High 1 = Active Low								
8	Output Configuration: 0 = Full push-pull 1 = Open drain								
10:9	00	Alarm_High_Cfg	Configure the Alarm_High output pin: <table border="1"> <thead> <tr> <th>Bits</th> <th>Description</th> </tr> </thead> <tbody> <tr> <td>9</td> <td>Alarm Polarity: 0 = Active High 1 = Active Low</td> </tr> <tr> <td>10</td> <td>Output Configuration: 0 = Full push-pull 1 = Open drain</td> </tr> </tbody> </table>	Bits	Description	9	Alarm Polarity: 0 = Active High 1 = Active Low	10	Output Configuration: 0 = Full push-pull 1 = Open drain
Bits	Description								
9	Alarm Polarity: 0 = Active High 1 = Active Low								
10	Output Configuration: 0 = Full push-pull 1 = Open drain								
*12	0	Ready_Open_Drain	Ready pin is 0 = Full push-pull 1 = Open drain						
*13	0	Fast_Startup	Sets the Command Window length: 0 = 10 ms Command Window 1 = 3 ms Command Window						
15:14	00	Reserved	Do Not Change – must leave at factory settings						

* Only applies to I2C output

Table 7.1

HumiChip Part Number List

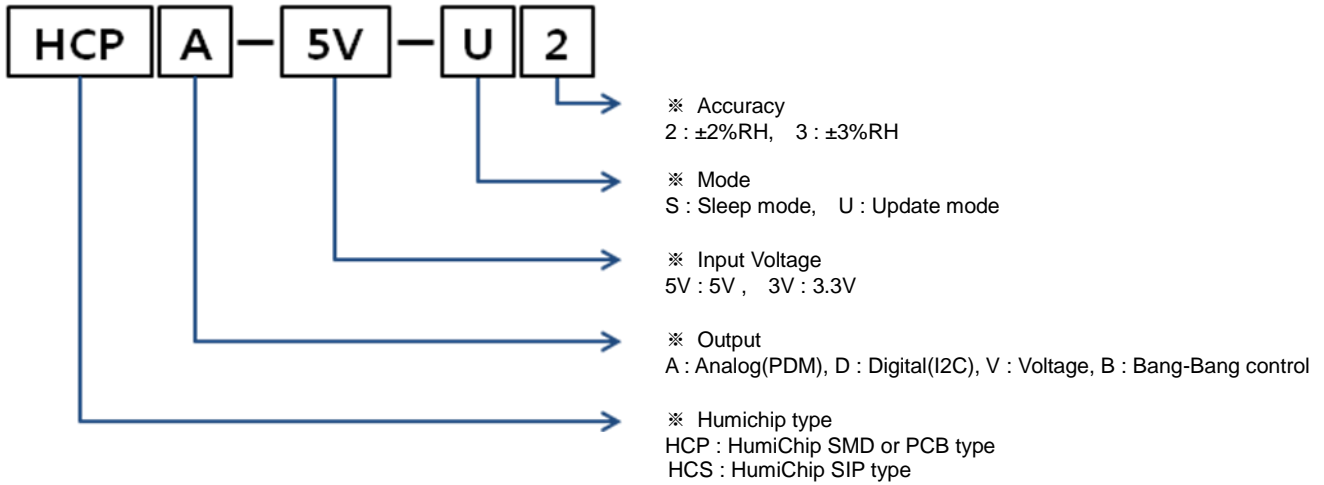

Items	Series	Output	Operating Voltage(V)	Mode	Accuracy(%RH)	Part Number
Humi A	HCP (SMD)	PDM (Analog)	5	Update	±2	HCPA-5V-U2
			5	Update	±3	HCPA-5V-U3
			3.3	Update	±2	HCPA-3V-U2
			3.3	Update	±3	HCPA-3V-U3
Humi D	HCP (SMD)	I2C (Digital)	5	Update	±2	HCPD-5V-U2
			5	Update	±3	HCPD-5V-U3
			3.3	Update	±2	HCPD-3V-U2
			3.3	Update	±3	HCPD-3V-U3
			5	Sleep	±2	HCPD-5V-S2
			5	Sleep	±3	HCPD-5V-S3
			3.3	Sleep	±2	HCPD-3V-S2
			3.3	Sleep	±3	HCPD-3V-S3

For further information about this Application Guide :

E-mail : sales@samyoungsnc.com or Phone : + 82 31 741-1830



SAMYOUNG S&C Co., Ltd.

150 Sangdaewon-dong, Jungwon-gu,
Sungnam-city, Kyongki-do,
KOREA 462-807

Phone: + 82 31 741-1830
Facmile: + 82 31 741-1821
Homepage: www.samyoungsn.com
E-mail: sales@samyoungsn.com

This Application Guide should be used only for intended and authorized application of **HumiChip®**.
Please consult with **SAMYOUNG S&C** for any specific application requirements and for detailed data sheet.
SAMYOUNG S&C reserve the rights, without further notice, to change the product specifications and/or the information in this document.

Copyright 2010[©], **SAMYOUNG S&C**