

This datasheet describes the use of the MiCS-4514. This is commonly, but not exclusively, used in automobile applications. The package and the mode of operation described in this document describe the detection of reducing gases such as CO and hydrocarbons, and oxidising gases such as NO<sub>2</sub>.

A typical application for this type of sensor is in areas that are subject to emissions from automobile exhausts.

### FEATURES

- Low heater current
- Wide detection range
- Wide temperature range
- High sensitivity
- Short pre-heating time
- Two sensors in one SMD package with miniature dimensions
- High resistance to shocks and vibrations
- Compliant with automotive test requirements

### OPERATING MODE

The recommended mode of operation is constant power on each sensor. The nominal power for the RED sensor is  $P_H = 76$  mW, while the nominal power for the OX sensor is  $P_H = 43$  mW. The resulting temperatures of the sensing layers are respectively about 340 °C and 220 °C, in air at approximately 20 °C.

Detection of the pollution gases is achieved by measuring the sensing resistance of both sensors:

- RED sensor resistance decreases in the presence of CO and hydrocarbons.
- OX sensor resistance increases in the presence of NO<sub>2</sub>.

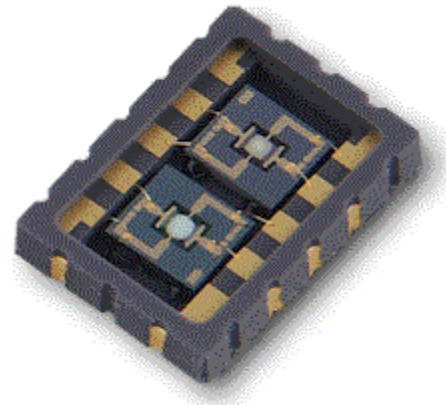

Product shown without cap

### SENSOR CONFIGURATION

The silicon gas sensor structure consists of an accurately micro machined diaphragm with an embedded heating resistor and the sensing layer on top.

The MiCS-4514 includes two sensor chips with independent heaters and sensitive layers. One sensor chip detects oxidising gases (OX) and the other sensor detects reducing gases (RED). The internal connections are shown below.

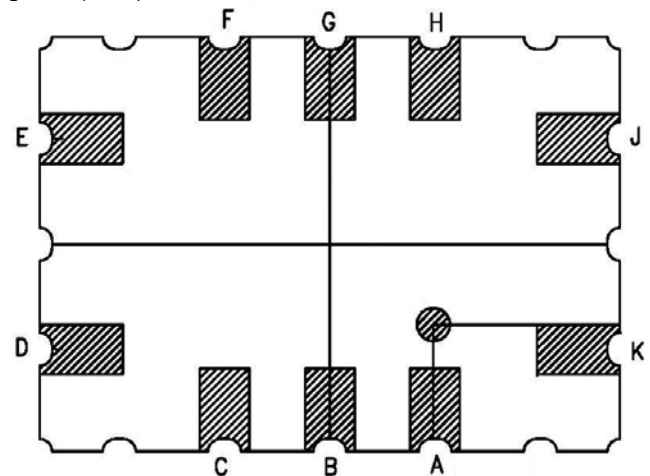

Pin	Connection
A	Rh1 OX
B	Rs1 OX
C	Rh1 RED
D	Rs1 RED
E	NC
F	Rh2 RED
G	Rs2 RED
H	Rh2 OX
J	Rs2 OX
K	NC

Rs: sensor resistance  
Rh: heater resistance

Figure 1: MiCS-4514 configuration (bottom view)

Whilst e2v technologies has taken care to ensure the accuracy of the information contained herein it accepts no responsibility for the consequences of any use thereof and also reserves the right to change the specification of goods without notice. e2v technologies accepts no liability beyond the set out in its standard conditions of sale in respect of infringement of third party patents arising from the use of tubes or other devices in accordance with information contained herein.

e2v technologies (uk) limited, Waterhouse Lane, Chelmsford, Essex CM1 2QU United Kingdom Telephone: +44 (0)1245 493493 Facsimile: +44 (0)1245 492492

e-mail: [enquiries@e2v.com](mailto:enquiries@e2v.com) Internet: [www.e2v.com](http://www.e2v.com) Holding Company: e2v technologies plc

e2v technologies inc. 4 Westchester Plaza, PO Box 1482, Elmsford, NY10523-1482 USA Telephone: (914) 592-6050 Facsimile: (914) 592-5148 e-mail: [enquiries@e2vtechnologies.us](mailto:enquiries@e2vtechnologies.us)

## POWER CIRCUIT EXAMPLE

As shown below, two external load resistors can be used to power both heaters with a single 5 V power supply.

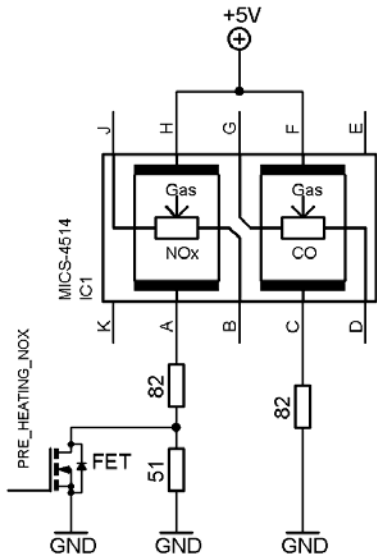

Figure 2: MiCS-4514 with recommended supply circuit (top view)

RDRED is 82 Ω and RDOX is 133 Ω. These resistors are necessary to obtain the right temperatures on the two independent heaters while using a single 5 V power supply. The resulting voltages are typically VHRED = 2.4 V and VHOX = 1.7 V.

## RED SENSOR CHARACTERISTICS

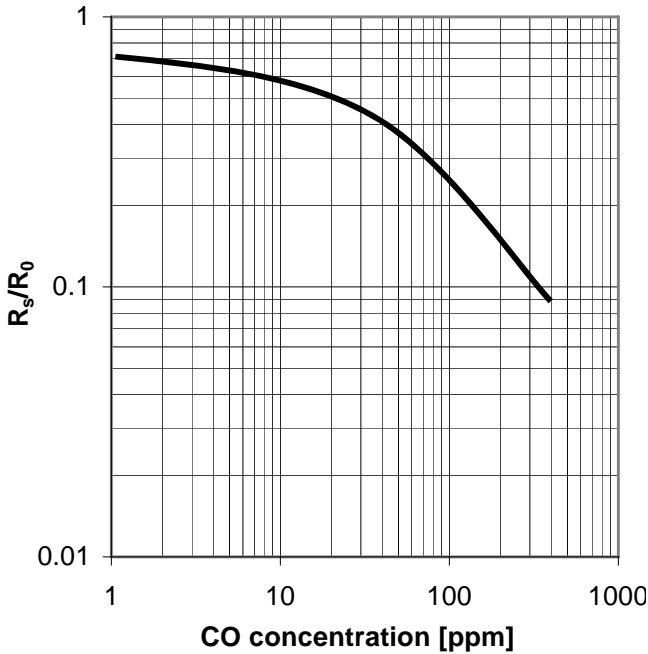

Figure 4:  $R_s/R_0$  as a function of CO concentration at 40% RH and 25 °C, measured on an engineering test bench

## MEASUREMENT CIRCUIT EXAMPLE

As shown below, the sensitive resistance shall be read by using a load resistor.

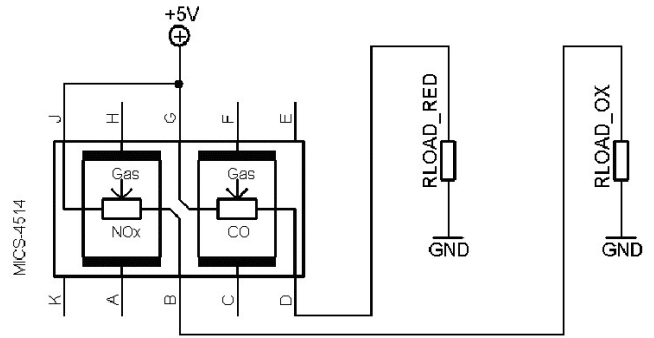

Figure 3: MiCS-4514 with measurement circuit (top view)

The two voltages measured on the load resistors are directly linked to the resistances of the RED and OX sensors respectively. RLOAD must be 820 Ω at the lowest in order not to damage the sensitive layer.

## OX SENSOR CHARACTERISTICS

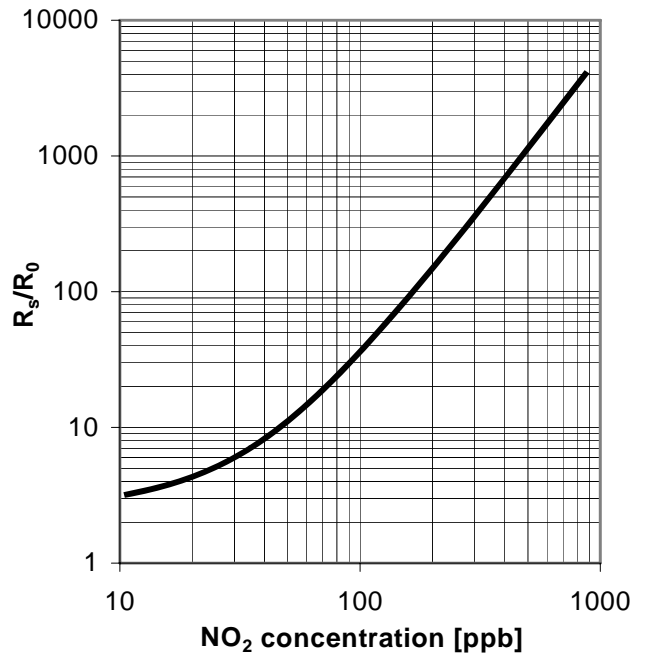

Figure 5:  $R_s/R_0$  as a function of NO<sub>2</sub> concentration at 40% RH and 25 °C, measured on an engineering test bench

## ELECTRICAL CHARACTERISTICS

Rating	Symbol	Value/Range	Unit
Maximum heater power dissipation	$P_H$	88 (RED sensor)/50 (OX sensor)	mW
Maximum sensitive layer power dissipation	$P_S$	8	mW
Voltage supply	$V_{supply}$	4.9 - 5.1	V
Relative humidity range	$R_H$	5 - 95	%RH
Ambient operating temperature	$T_{amb}$	-30 - 85	°C
Storage temperature range	$T_{sto}$	-40 - 120	°C
Storage humidity range	$RH_{sto}$	5 - 95	%RH

## OPERATING CONDITIONS (RED Sensor/OX Sensor)

Parameter	Symbol	Typ	Min	Max	Unit
Heating power	$P_H$	76/43	71/30	81/50	mW
Heating voltage	$V_H$	2.4/1.7	-	-	V
Heating current	$I_H$	32/26	-	-	mA
Heating resistance at nominal power	$R_H$	74/66	66/59	82/73	$\Omega$

## SENSITIVITY CHARACTERISTICS

Characteristic (RED Sensor)	Symbol	Typ	Min	Max	Unit
CO detection range	FS		1	1000	ppm
Sensing resistance in air (see note 1)	$R_0$	-	100	1500	$k\Omega$
Sensitivity CO 60 ppm (see note 2)	$S_{60}$	-	5	50	-

Characteristic (OX Sensor)	Symbol	Typ	Min	Max	Unit
NO <sub>2</sub> detection range	FS		0.05	5	ppm
Sensing resistance in air (see note 1)	$R_0$	-	0.8	20	$k\Omega$
Sensitivity factor (see note 3)	$S_R$	-	6	-	-

### Notes:

1. Sensing resistance in air  $R_0$  is measured under controlled ambient conditions, i.e. synthetic air at  $23 \pm 5$  °C and  $50 \pm 10\%$  RH for RED sensor and synthetic air at  $23 \pm 5$  °C and  $\leq 5\%$  RH for OX sensor. Sampling test.
2. Sensitivity CO 60 ppm is defined as  $R_S$  in air divided by  $R_S$  at 60 ppm CO. Test conditions are  $23 \pm 5$  °C and  $50 \pm 10\%$  RH. Indicative values only, sampling test.
3. Sensitivity factor is defined as  $R_S$  at 0.25 ppm of NO<sub>2</sub>, divided by  $R_S$  in air. Test conditions are  $23 \pm 5$  °C and  $\leq 5\%$  RH. Indicative values only, sampling test.

## IMPORTANT PRECAUTIONS

Read the following instructions carefully before using the MiCS-4514 described in this document to avoid erroneous readings and to prevent the device from permanent damage.

- The sensor must be reflow soldered in a neutral atmosphere, without soldering flux vapours.
- The sensor must not be exposed to high concentrations of organic solvents, ammonia, silicone vapour or cigarette-smoke in order to avoid poisoning the sensitive layer.
- Heater voltages above the specified maximum rating will destroy the sensor due to overheating.
- This sensor is to be placed in a filtered package that protects it against water and dust projections.
- e2v strongly recommends using ESD protection equipment to handle the sensor.
- For any additional questions, contact e2v.

## PACKAGE OUTLINE DIMENSIONS

The package is compatible with SMD assembly process.

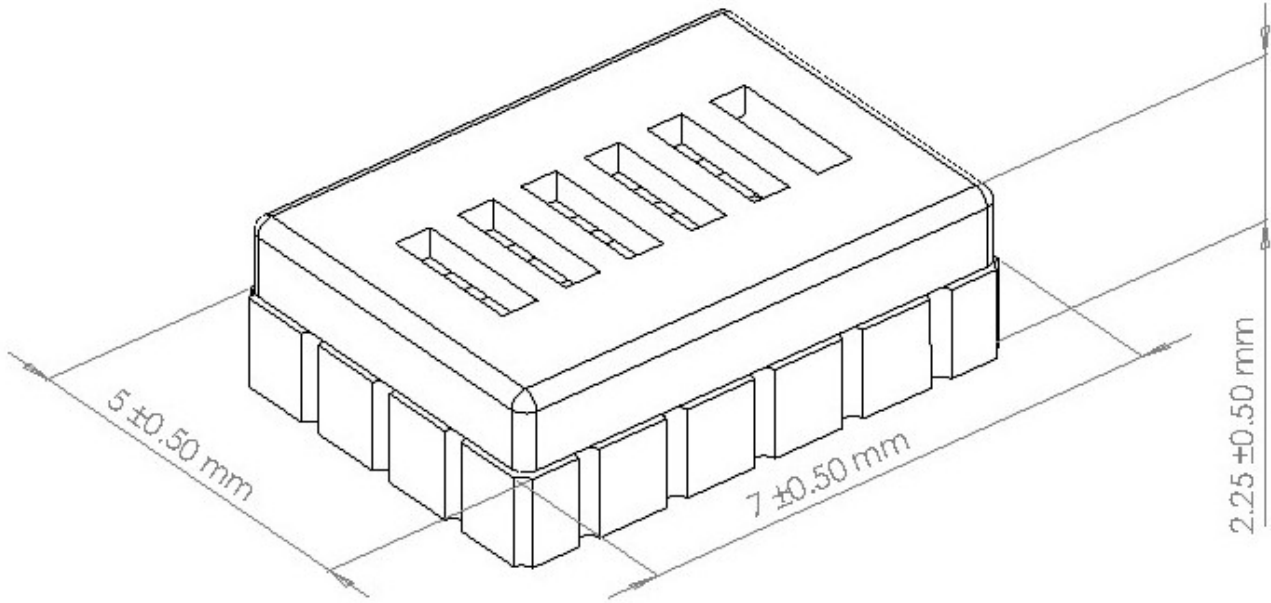

## SOLDERING PADS GEOMETRY

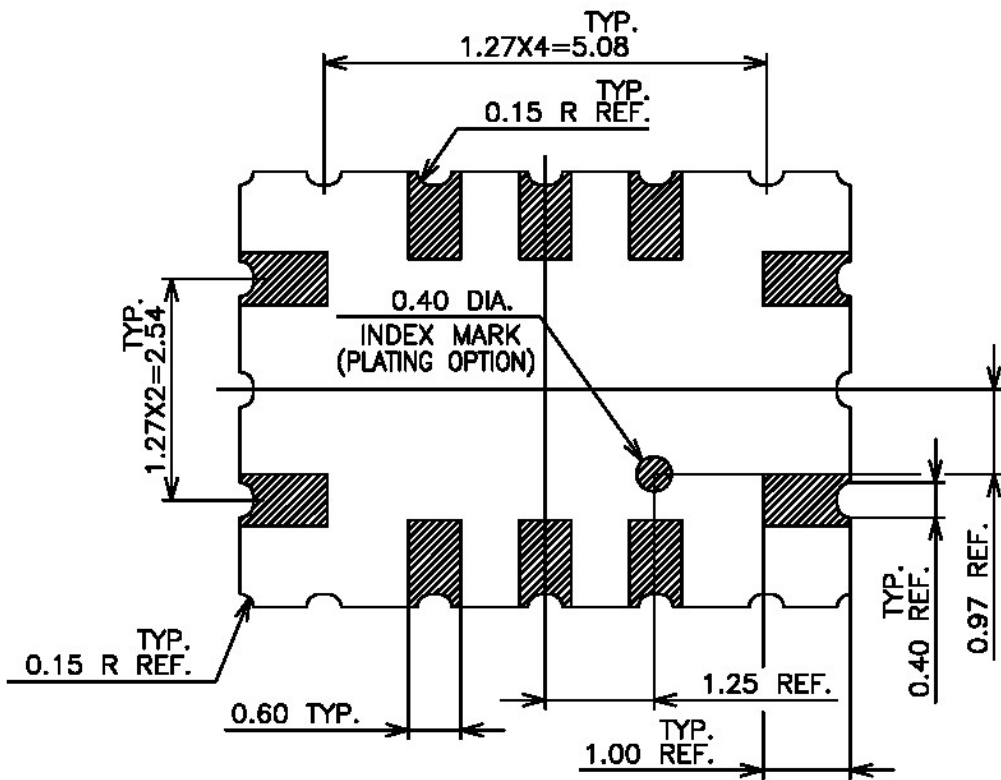

# PACKAGING TAPE AND REEL FOR EXPEDITION

The sensors are placed in a carrier tape. The dimensions of the cavity are 5.5 x 7.5 x 2.55 mm (the tolerance is ±0.2 mm).

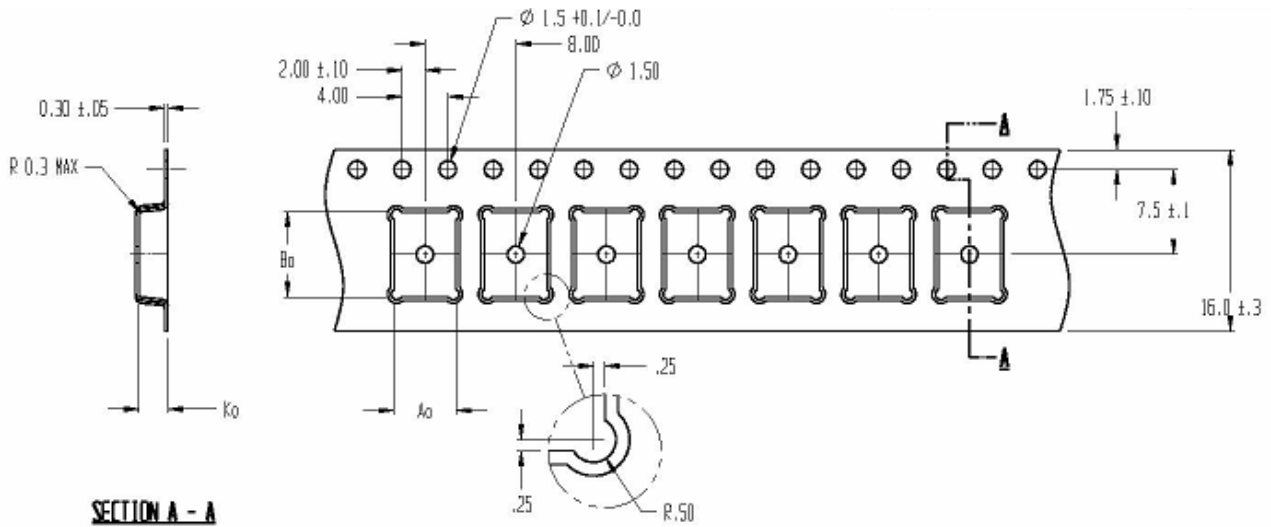

The outside diameter of the reel is either 178 ± 1 mm (for a maximum of 700 sensors) or 330 +0.25 / -4 mm (for a maximum of 2000 sensors).

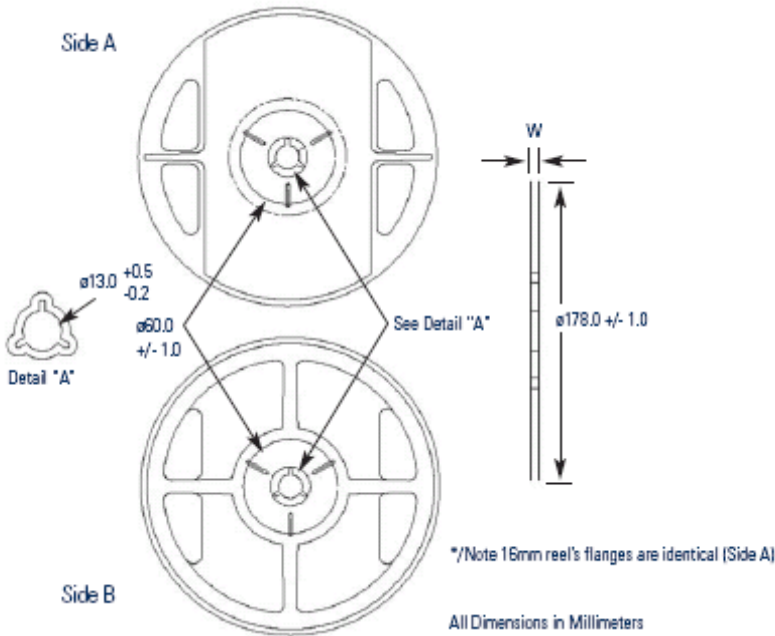

e2v semiconductor gas sensors are well suited for leak detection and applications requiring limited accuracy. Their use for absolute gas concentration detection is more complicated because they typically require temperature compensation, calibration, and sometimes as well, humidity compensation. Their base resistance in clean air and their sensitivity can vary overtime depending on the environment they are in. This effect must be taken into account for any application development (278-11.0).